

INSTALLATION & OWNER'S MANUAL

The ALPINA LARGE - VIEW SAUNA

Read these instructions to guide your assembly.



It is highly recommended to view the assembly video prior to starting assembly!

This product manufactured by

ALMOST HEAVEN
SAUNAS





IMPORTANT SAFETY INSTRUCTIONS

DANGER: Indicates a hazardous situation that, if not avoided, will result in death or serious injury.

WARNING: Indicates a hazardous situation that, if not avoided, could result in death or serious injury.

CAUTION: Indicates a hazardous situation that, if not avoided, could result in minor or moderate injury.

NOTICE: Indicates information considered important, but not hazard-related.

-  **READ ALL INSTRUCTIONS BEFORE INSTALLATION AND USE TO AVOID INJURY OR DAMAGE TO SAUNA**
-  **FOLLOW SAFETY INFORMATION IN THIS DOCUMENT TO AVOID SERIOUS INJURY OR DEATH**
-  **REFER TO YOUR LOCAL BUILDING CODES FOR ANY SPECIFIC INSTALLATION REQUIREMENTS**
-  **ALL ELECTRICAL WORK NEEDS TO BE COMPLETED BY A LICENSED ELECTRICIAN. FAILURE TO DO SO COULD CAUSE INJURY OR DAMAGE TO THE HEATER.**
-  **KEEP THESE INSTRUCTIONS FOR FUTURE REFERENCE**

WARNING

- This sauna is not intended for use by persons (including children) with reduced physical, sensory or mental capabilities, or lack of experience and knowledge, unless they have been given supervision or instruction concerning use of the sauna by a person responsible for their safety.
 - Consult your doctor about any health-related limitations related to sauna use. Ignoring advice from your medical provider could cause serious injury or death.
 - Do not let people with pre-existing health conditions bathe in the sauna on their own. Using the sauna could cause these users to lose consciousness.
 - Parents should consult your pediatrician before allowing children to use the sauna. Ignoring advice from your medical provider could cause serious injury or death.
 - Do not smoke, use alcohol, or exercise in the sauna. These tasks could cause users to lose consciousness.
 - Do not exceed 30 min. in the sauna at one time, as excessive exposure may be harmful to health.
The sauna should not be used as an endurance test.
 - Do not place any combustible material over the sauna heater (towels, bathing suits, wooden bucket or ladle)!
This will cause the sauna to catch fire.
 - Hyperthermia occurs when the internal temperature of the body reaches a level several degrees above the normal body temperature of 98,6 °F. The symptoms of hyperthermia include an increase in the internal temperature of the body, dizziness, lethargy, drowsiness, and fainting.
- Only use stones approved for sauna heater use. Inadequate stones may crack or explode leading to serious injury.

This product manufactured by

ALMOST HEAVEN
SAUNAS



- Do not sleep in a sauna that the heater is operating. Sleeping in a heated sauna may lead to injury or death.

CAUTION

- Keep all occupants away from the heater and when it is hot. The stones and outer surface of the heater may burn your skin.
- Do not throw excessive amounts of water on the stones. The evaporating water is boiling hot and could cause burns.
- Do not throw water directly onto the elements. This could cause burns and damage to the heater.
- Be very careful when moving in the sauna, as the benches and floors may be slippery. This could cause the user to slip and fall.
- Do not alter the sauna in any way, unless explicitly instructed in this manual. Altering the sauna could lead to structural damage, increasing the risk to bodily harm.
- When moving and lifting heavy pieces, use two or more people. Moving pieces without adequate manpower will lead to injury.

A WORD ABOUT OUR SAUNAS

Our sauna kits are designed for ease of assembly by the customer, and every attempt has been made to make assembly information as clear as possible. If you have any questions about assembly, please do not hesitate to call us at **773-435-7596**, or send us an email at support@rateoutdoors.com.

Thank you again for choosing Almost Heaven. We are grateful for your business and know you will have many years of enjoyment in your sauna!

Your Almost Heaven sauna is designed for outdoor use although it is perfectly fine to use it indoors. The lumber is naturally resistant to the elements. Rain and sun will not damage the wood, although natural weathering and coloring of the wood will occur over time. To preserve the initial look of the sauna, you may choose to stain the exterior with a UV inhibiting stain. Consult your local paint store for their recommendations on a particular stain for your sauna. We do not recommend that you paint or varnish inside your sauna. Properly assembled, you should not experience water dripping in the sauna.

LOCATING THE SAUNA

Because the traditional sauna experience involves a heating-cooling-resting regimen, it is important to plan ahead before installing your sauna. Our method of construction allows you to place your sauna in a wide variety of settings.

Be sure the surface is firm and level, and can support the weight of the sauna and its users (1,000+ lbs). A deck or concrete slab is certainly an option, but if your sauna sits directly on the ground, be sure the base boards sit on paver stones or something similar to prevent the sauna from settling into the ground.

This product manufactured by

ALMOST HEAVEN
SAUNAS



BASIC TOOLS

These tools are helpful in the assembly of your barrel sauna:

- Cordless Drill
 - Drill Bit Set
 - Bit Set
 - Rubber Mallet
 - Hammer
 - Framing square
 - 1/4" Hex Bit
 - Utility knife
 - Level
 - Tape Measure
 - Ladder
- Table or Skill Saw

FIRST CONSIDERATIONS

Before beginning assembly, ensure that the installation surface is level. Many garage, basement or deck floors are sloped for drainage. A slight slope will not be an issue, but a more pronounced slope will require shimming to make the sauna level. An uneven installation surface can result in poor-fitting staves leading to poor sauna function. Also, if the site might receive heavy winds, it is recommended extra precautions are taken to ensure the door does not blow open. In most situations, this factor will not be a concern.

ELECTRICAL REQUIREMENTS

Costs of an electrician can vary greatly depending on several factors, including your sauna's distance from your electrical service box, where you live and cost of materials. We always recommend you get quotes from two to three different licensed electricians before you begin installation in order to get the best possible service and price.

Use copper wire with 90C insulation. Do not use aluminum wire to make the connection. Consult with an electrician so you can determine the requirements for your particular situation. All wiring must conform to all national, state and local codes and regulations.

For further information and instruction on your heater installation and operation, please consult the provided heater manual.

This product manufactured by

**ALMOST HEAVEN**
SAUNAS



PARTS LIST

No. of items	Name	Dimensions inches
Floor frame, outer		
1	Floor frame (impregnated) - left	84- ⁵ / ₈ x 3- ¹ / ₈ x 3- ¹ / ₈
1	Floor frame (impregnated) - right	84- ⁵ / ₈ x 3- ¹ / ₈ x 3- ¹ / ₈
1	Floor frame (impregnated) - front	62- ¹ / ₄ x 3- ¹ / ₈ x 3- ¹ / ₈
1	Floor frame (impregnated) - front	78- ³ / ₄ x 3- ¹ / ₈ x 3- ¹ / ₈
1	Floor frame (impregnated) - rear	62- ¹ / ₄ x 3- ¹ / ₈ x 3- ¹ / ₈
1	Floor frame (impregnated) - rear	78- ³ / ₄ x 3- ¹ / ₈ x 3- ¹ / ₈
Floor frame, inner		
1	Base frame (impregnated) - middle	80- ³ / ₄ x 3- ¹ / ₈ x 3- ¹ / ₈
2	Base frame (impregnated)	78- ³ / ₈ x 3- ¹ / ₈ x 2- ³ / ₈
2	Base frame (impregnated)	46- ¹ / ₂ x 3- ¹ / ₈ x 2- ³ / ₈
4	Base frame (impregnated)	79- ¹ / ₂ x 3- ¹ / ₈ x 1- ⁵ / ₈
4	Base frame (impregnated)	47- ⁵ / ₈ x 3- ¹ / ₈ x 1- ⁵ / ₈
1	Base frame (impregnated)	13- ¹ / ₂ x 3- ¹ / ₈ x 1- ⁵ / ₈
1	Base frame (impregnated)	23- ⁵ / ₈ x 3- ¹ / ₈ x 1- ⁵ / ₈
34	Floor boards	76- ³ / ₄ x 4- ¹ / ₈ x ³ / ₄
1	Floor board	54- ³ / ₄ x 4- ¹ / ₂ x ³ / ₄
3	Skirting board 2x45° - left, right, middle	77- ¹ / ₈ x 1 x ³ / ₄
1	Skirting board 1x45° - front	77- ¹ / ₈ x 1 x ³ / ₄
2	Skirting board 1x45° - middle	23- ¹ / ₄ x 1 x ³ / ₄
1	Skirting board 2x45° - rear	45- ¹ / ₄ x 1 x ³ / ₄
1	Skirting board 1x45° - front	45- ¹ / ₄ x 1 x ³ / ₄
Wall elements		
1	Wall element W1 - Electrical element	100- ¹ / ₂ x 14- ¹ / ₈ x 4- ³ / ₈
1	Wall element W2	100- ¹ / ₂ x 26- ³ / ₄ x 4- ³ / ₈
1	Wall element W3	50- ¹ / ₈ x 34- ³ / ₈ x 4- ³ / ₈
1	Wall element W3-b	20- ³ / ₄ x 33- ⁷ / ₈ x 4- ³ / ₈
1	Wall element W4	96- ¹ / ₈ x 25- ³ / ₈ x 4- ³ / ₈
1	Wall element W5 - Electrical element	94 x 22- ¹ / ₈ x 4- ³ / ₈
1	Wall element W6	94 x 24- ³ / ₈ x 4- ³ / ₈
1	Wall element W7 - Electrical element	94 x 24- ³ / ₈ x 4- ³ / ₈
1	Wall element W8	94 x 24- ³ / ₈ x 4- ³ / ₈
1	Wall element W9	94 x 24- ³ / ₈ x 4- ³ / ₈
1	Wall element W10 - Electrical element	94 x 19- ¹ / ₄ x 4- ³ / ₈
1	Wall element W11 - Ventilation element	95- ⁵ / ₈ x 20 x 4- ³ / ₈
1	Wall element W12	97- ³ / ₈ x 24- ³ / ₈ x 4- ³ / ₈
1	Wall element W13	99- ¹ / ₈ x 24- ³ / ₈ x 4- ³ / ₈
1	Wall element W14 - Electrical element	100- ¹ / ₂ x 18- ³ / ₄ x 4- ³ / ₈
1	Wall element W15	100- ¹ / ₂ x 27- ¹ / ₄ x 4- ³ / ₈
1	Wall element W16	10 x 34- ³ / ₈ x 4- ³ / ₈
1	Wall element W16-b	22- ⁵ / ₈ x 33- ⁷ / ₈ x 4- ³ / ₈
1	Wall element W17 - Electrical / Ventilation element	100- ¹ / ₂ x 24- ³ / ₈ x 4- ³ / ₈
1	Wall element W18	100- ¹ / ₂ x 37- ³ / ₄ x 4- ³ / ₈
2	Mounting rail W3, W16	63- ³ / ₄ x 3- ¹ / ₈ x 1- ⁵ / ₈

No. of items	Name	Dimensions inches
Corner posts		
4	Corner posts	79- ⁷ / ₈ x 3- ¹ / ₈ x 3- ¹ / ₈
Partition wall		
1	Mounting rail - rear	81- ³ / ₈ x 1- ⁷ / ₈ x 1
1	Wall element W19	82- ¹ / ₄ x 22- ¹ / ₄ x 3- ¹ / ₈
1	Stand with multiclip - rear	80- ⁵ / ₈ x 3- ³ / ₄ x 3- ¹ / ₈
1	Mounting rail - front	80- ⁵ / ₈ x 1- ⁷ / ₈ x 1
1	Stand with groove for glass - front	80- ⁵ / ₈ x 3- ¹ / ₈ x 3- ¹ / ₈
1	Element above door, with seal	49- ³ / ₈ x 3- ¹ / ₈ x 2- ³ / ₄
1	Spacer bar - above door	27- ¹ / ₈ x ³ / ₄ x ³ / ₈
Glass elements - partition wall		
1	Glass door	77- ³ / ₄ x 26- ³ / ₄ x ³ / ₈
1	Glass element	79 x 22- ⁷ / ₈ x ³ / ₈
Ceiling		
1	Roof support strip L1	84- ⁵ / ₈ x 3- ¹ / ₈ x 1- ⁵ / ₈
1	Roof support strip L2	66- ¹ / ₂ x 3- ¹ / ₈ x 1- ⁵ / ₈
1	Roof support strip L3	66- ¹ / ₂ x 3- ¹ / ₈ x 1- ⁵ / ₈
1	Roof support strip L4	84- ⁵ / ₈ x 3- ¹ / ₈ x 1- ⁵ / ₈
1	Roof support strip L5	66- ¹ / ₂ x 3- ¹ / ₈ x 1- ⁵ / ₈
1	Roof support strip L6	66- ¹ / ₂ x 3- ¹ / ₈ x 1- ⁵ / ₈
1	Roof element D1	83- ⁷ / ₈ x 21- ¹ / ₈ x 3- ⁷ / ₈
1	Roof element D2 - Inspection opening	83- ⁷ / ₈ x 24- ³ / ₈ x 3- ⁷ / ₈
1	Roof element D3 - Electrical element	83- ⁷ / ₈ x 24- ³ / ₈ x 3- ⁷ / ₈
2	Roof element D4, D5	83- ⁷ / ₈ x 24- ³ / ₈ x 3- ⁷ / ₈
1	Roof element D6	83- ⁷ / ₈ x 18- ¹ / ₄ x 3- ⁷ / ₈
Roof		
1	Rafter support - rear	54- ³ / ₈ x 3- ¹ / ₈ x 2- ³ / ₄
1	Rafter support - rear	78- ³ / ₄ x 3- ¹ / ₈ x 2- ³ / ₄
1	Rafter support - front, bottom	54- ³ / ₈ x 4- ⁵ / ₈ x 2- ³ / ₄
1	Rafter support - front, bottom	54- ³ / ₈ x 4- ⁵ / ₈ x 2- ³ / ₄
1	Rafter support - front, top	78- ³ / ₄ x 4- ⁵ / ₈ x 2- ³ / ₄
1	Rafter support - front, top	78- ³ / ₄ x 4- ⁵ / ₈ x 2- ³ / ₄
7	Roof rafters	84- ⁷ / ₈ x 5- ¹ / ₂ x 2- ³ / ₄
4	Roof panels	69- ¹ / ₈ x 45 x ³ / ₄
Windows		
4	Mounting rails	63- ³ / ₄ x 2 x 1- ³ / ₈
2	Mounting rails	25 x 2 x 1- ³ / ₈
2	Mounting rails	65 x 2 x 1- ³ / ₈
1	Window	63- ³ / ₈ x 27- ³ / ₈ x 4- ³ / ₈
1	Window	63- ³ / ₈ x 67- ¹ / ₂ x 4- ³ / ₈
4	Window frame - inner	58- ⁷ / ₈ x 2- ³ / ₄ x ³ / ₄
2	Window frame - inner	28- ¹ / ₄ x 2- ³ / ₄ x ³ / ₄
2	Window frame - inner	68- ¹ / ₂ x 2- ³ / ₄ x ³ / ₄
2	Window frame - outer	25- ¹ / ₈ x 2 x ³ / ₄
2	Window frame - outer	65- ¹ / ₄ x 2 x ³ / ₄
2	Window frame - outer	61- ⁵ / ₈ x 2- ¹ / ₄ x ³ / ₄
2	Window frame - outer	61- ⁵ / ₈ x 3- ³ / ₄ x ³ / ₄



PARTS LIST CONTINUED

No. of items	Name	Dimensions inches
Door outside		
2	Mounting rails	75-1/2 x 2 x 1-1/8
1	Mounting rail	33-3/8 x 2 x 1-1/8
1	Door	76-1/2 x 32-5/8 x 11
2	Door cover strip, inside	75-1/2 x 2-3/8 x 3/4
1	Door cover strip, inside	29-1/2 x 2-3/8 x 3/4
2	Door cover strip, outside	74-1/4 x 2 x 3/4
1	Door cover strip, outside	33-1/4 x 2-1/4 x 3/4
1	Door cover strip, outside	33-1/4 x 2 x 3/4
Decor, exterior		
1	Exterior decor D1	100-1/4 x 35 x 2
1	Exterior decor D2	10-1/4 x 35 x 2
1	Exterior decor D2-b	23-3/8 x 35 x 2
1	Exterior decor D3	100-1/4 x 35 x 2
1	Exterior decor D4	100-1/4 x 34-1/8 x 2
1	Exterior decor D5	99-7/8 x 30-3/8 x 2
1	Exterior decor D6	50-3/8 x 30-3/8 x 2
1	Exterior decor D6-b	21 x 30-3/8 x 2
1	Exterior decor D7	95-1/2 x 29-1/2 x 2
1	Exterior decor D8	93-1/2 x 35 x 2
1	Exterior decor D9	93-1/2 x 35 x 2
1	Exterior decor D10	93-1/2 x 35 x 2
1	Exterior decor D11	93-1/2 x 34-1/8 x 2
1	Exterior decor D12	95-1/2 x 30-3/8 x 2
1	Exterior decor D13	97-3/4 x 30-3/8 x 2
1	Exterior decor D14	100 x 29-1/2 x 2
1	Mounting rail - below the door	33-1/4 x 1-5/8 x 1-1/8
Interior fittings		
5	Bench support slats	22-7/8 x 1-5/8 x 1-5/8
2	Bench support slats	47-1/4 x 1-5/8 x 1-5/8
2	Mounting slats for bench screen	10-1/4 x 1-5/8 x 1-5/8
1	Bench	70-1/2 x 24-3/8 x 3-1/2
1	Bench	52-1/2 x 24-3/8 x 3-1/2
1	Bench	44-7/8 x 24-3/8 x 3-1/2
1	Backrest	74-3/4 x 10-1/4 x 1-3/4
1	Backrest	71-1/4 x 10-1/4 x 1-3/4
1	Bench screen	70-1/2 x 13-3/4 x 1-5/8
1	Bench foot	48 X 36-1/4 X 2-3/8
15	Corner cover strips	79-1/2 x 1 x 3/8

No. of items	Name	Dimensions inches
Accessories		
1	Ventilation slide - inside	20-1/2 x 5-1/2 x 5/8
1	Ventilation slide - inside	11-1/4 x 4-3/4 x 5/8
2	Ventilation grille - outside	11-1/4 x 4-3/4 x 5/8
6	Sauna ventilation cover, stainless steel	Ø2-1/2
1	Floor grid	27-1/2 x 20-7/8 x 1-5/8
2	Headrests	16-7/8x 10-1/4 x 2-3/4
1	Lamp protective grille 920S	
1	Lamp without bulb	
1	Door handle set Alpina - exterior door	25-3/8
1	Door handle set wood/stainless steel - interior door	
1	Doormagnet, sleeve plate	
3	Door hinges 3308	
1	U-aluminium profile	22-3/8
1	19' 8" silicon cables: 5 x 10 Gauge	
1	13' 1" silicon cables: 3 x 15 Gauge	
3	Spacers for door and window installation	4 x 1-5/8 x 1/4
1	Roofing felt	107-5/8 ft ²
1	Installation material set	
1	Assembly instructions	

This product manufactured by

FLOOR/FOUNDATION PLAN

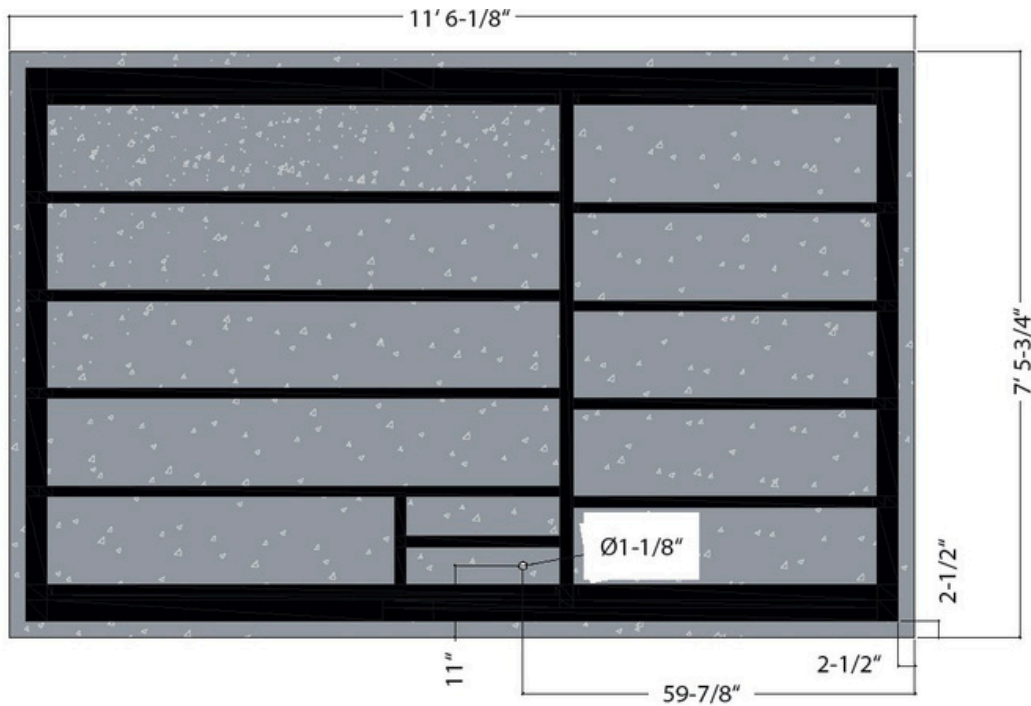
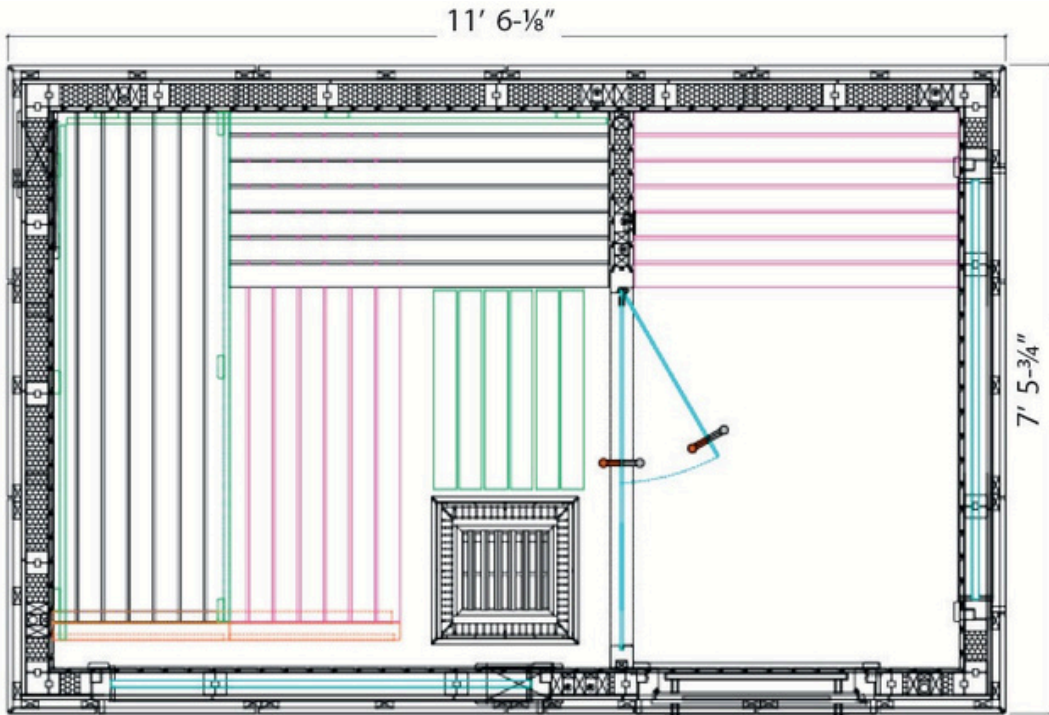

BASE ASSEMBLY



•Ensure sauna foundation is sturdy, level, and can carry the weight of the sauna. If the foundation is not, the sauna could tilt, shift or fall leading to injury. It is recommended to use a moisture

the base wood and the sauna foundation. We also recommend anchoring the sauna to the sauna foundation to prevent damage in the event of strong winds.

Place the outer floor frames centered on your foundation per the floor plan (1). Attach the floor frames together by predrilling and using fourteen 5 X 70 screws.

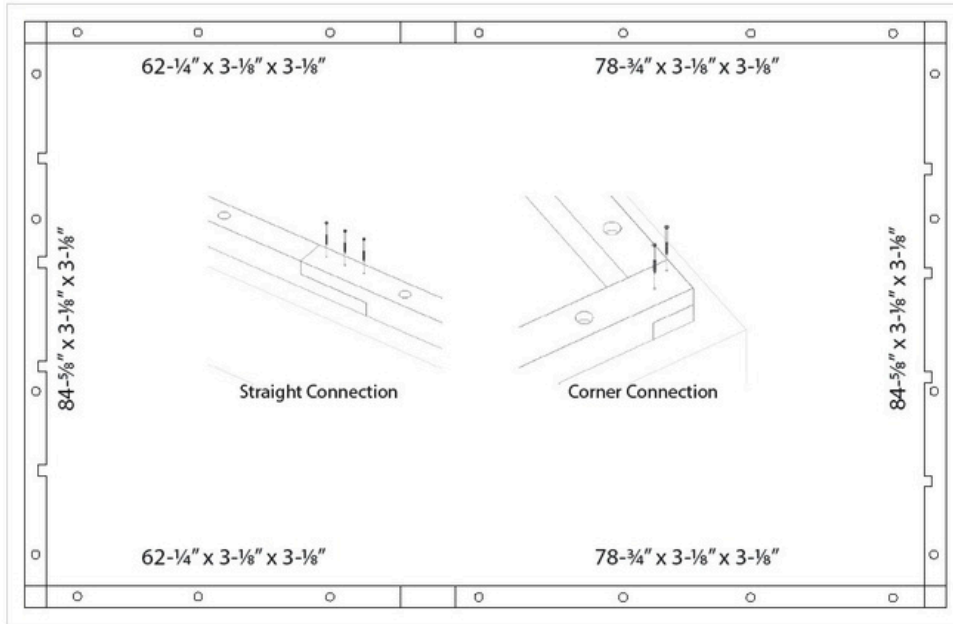

Image 1

Place the inner base floor frames inside the outer floor frames per the floor plan (2). Attach the inner base floor frames together by predrilling and using thirty-two 5 X 90 screws.

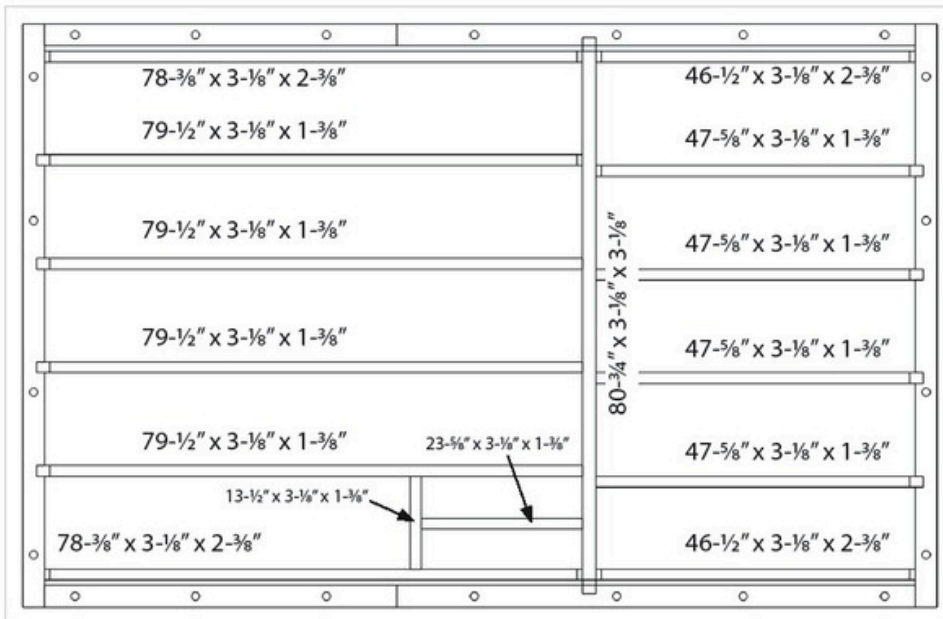
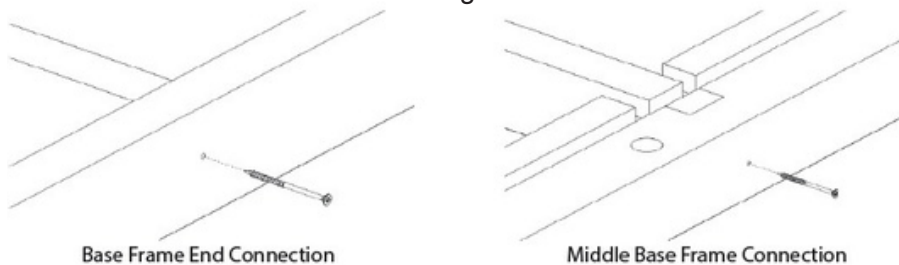

Image 2



**WALL ASSEMBLY
NOTICE**

- **ALL SCREWS MUST BE PREDRILLED BEFORE INSTALLING TO PREVENT BREAKAGE.**
- **Never hit the groove of the wall panels directly with a hammer, use a wooden strip/block in between.**
- **Check that the corners are a right angle when connecting before full fastening.**

Start by fastening wall element 1 (W1) and wall element 2 (W2) to a corner post in the front right base corner by using four 6 X 130 screws (3-4). Then attach wall W3 to W2 by using one 5 X 70 screw (5). Similarly, attach wall W4 to W3 by using one 5 X 70 screw; and then connect W2 and W4 using W3 Mounting Rail and six 5 X 70 screws. Then place wall W3-b on top of the mounting rail (6). Attach the next corner post to the other side of wall W4 using four 6 X 130 screws (7).

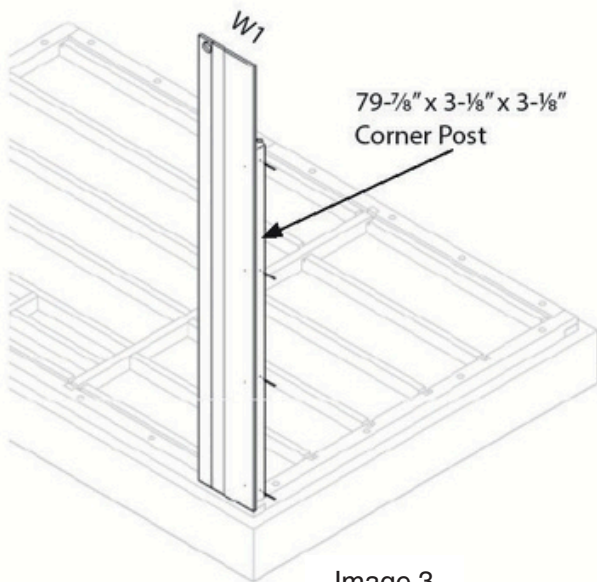

Image 3

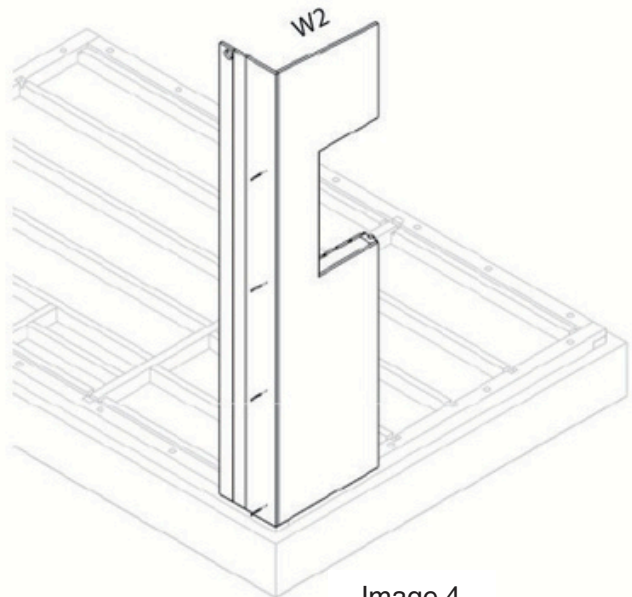

Image 4

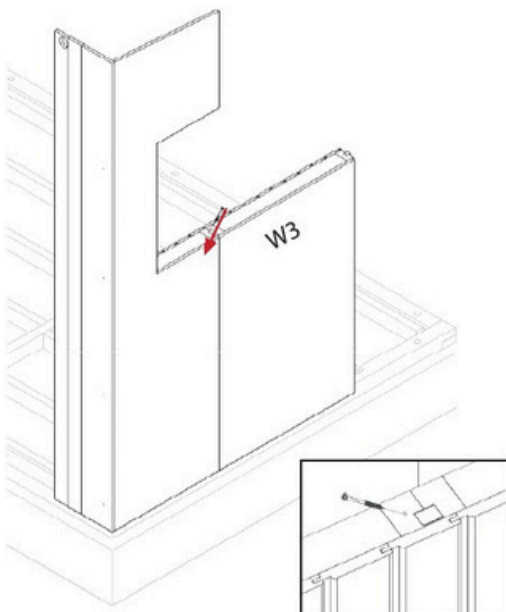

Image 5

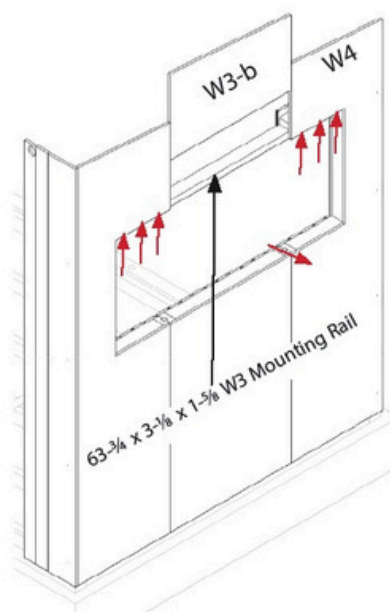

Image 6



Image 7

Next fasten wall W5 to the corner post using four 6 X 130 screws (8). Place walls W6, W7, W8, W9, W10 and fasten using five 5 X 70 screws (one in each connection) at the top of the wall joint (9). Fasten W3-b to W2 and W4 in the same manner. Place the next corner post and fasten to W10 using four 6 X 130 screws (10). Fasten wall W11 to the corner post using four 6 X 130 screws (11). Then place walls W12, W13, and W14 and fasten using three 5 X 70 screws (one in each connection) at the top of the wall joint (12). Place the last corner post and fasten to wall W14 using four 6 X 130 screws (13).

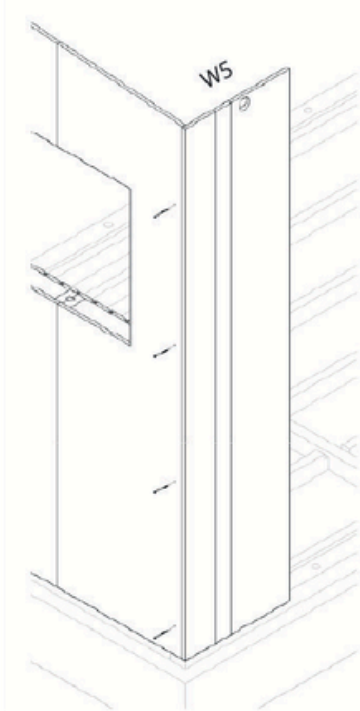

Image 8

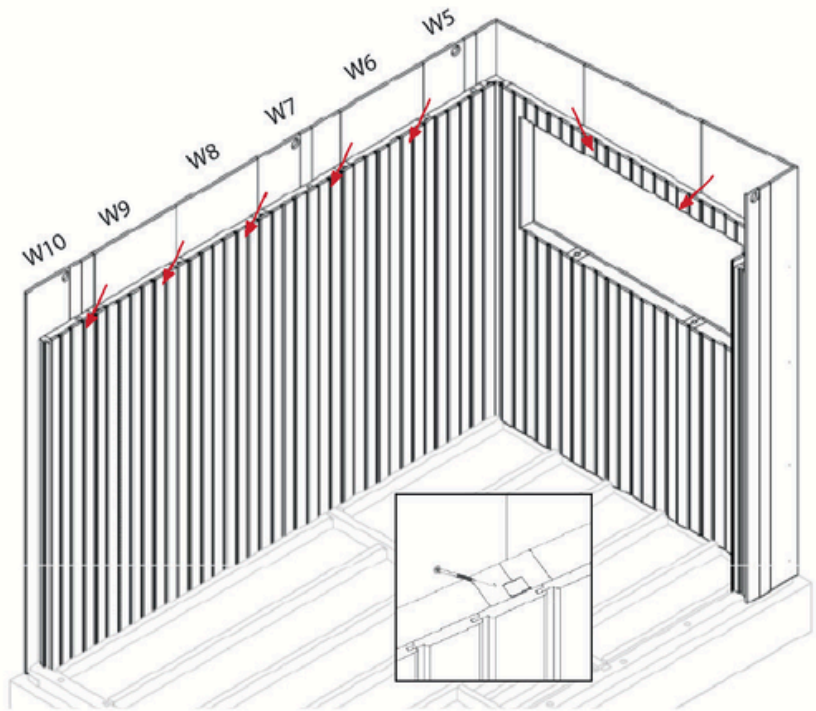

Image 9

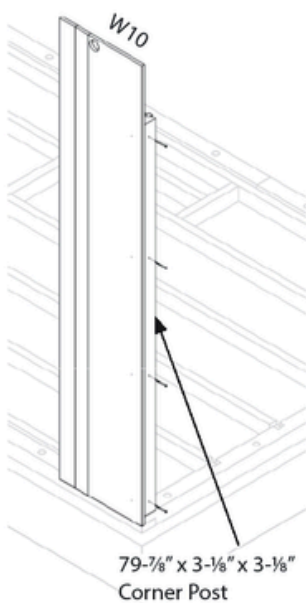

Image 10

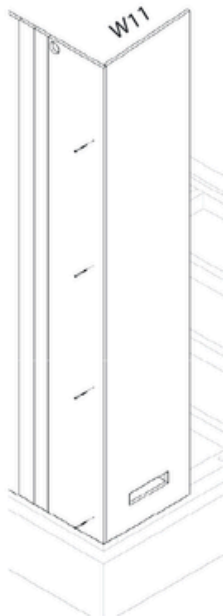

Image 11

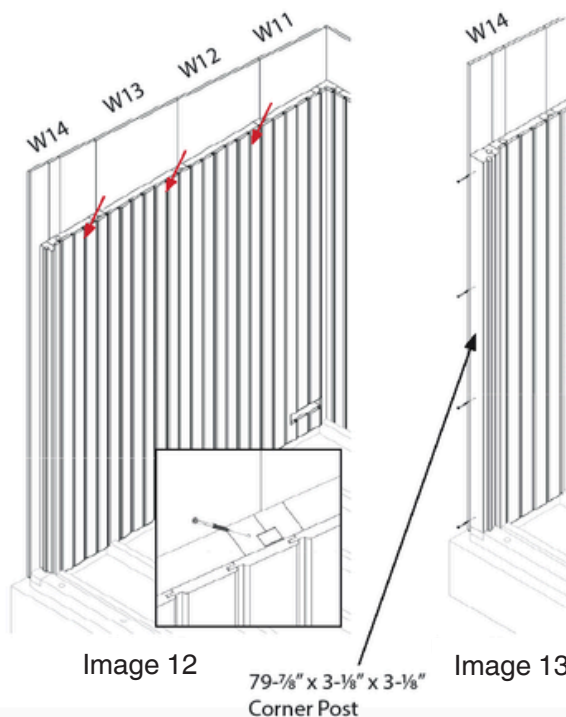

Image 12

Image 13

Connect wall W15 to the corner post using four 6 X 130 screws. Place wall W16 and W17 and fasten using one 5 X 70 screw in each connection (14). Connect W15 and W17 using W16 Mounting Rail and six 5 X 70 screws similar to W3 rail above, and install wall W16-b (15). Connect W16-b to W15 and W17 using 5 X 70 screws. To complete the outer wall assembly, place wall W18 (door frame element) between W17 and W1 and fasten using two 5 X 70 screws (one in each connection) at the top of the wall joint (16).

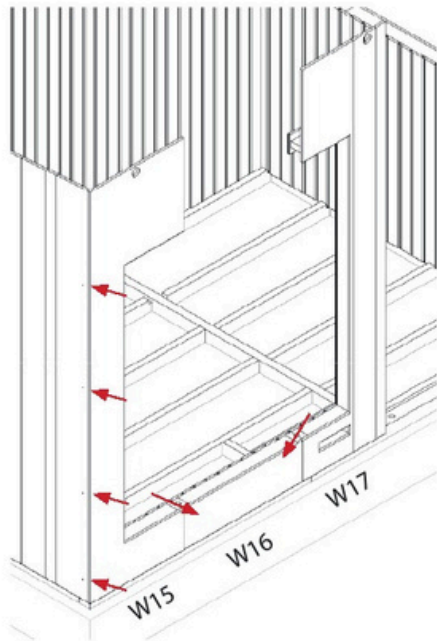

Image 14

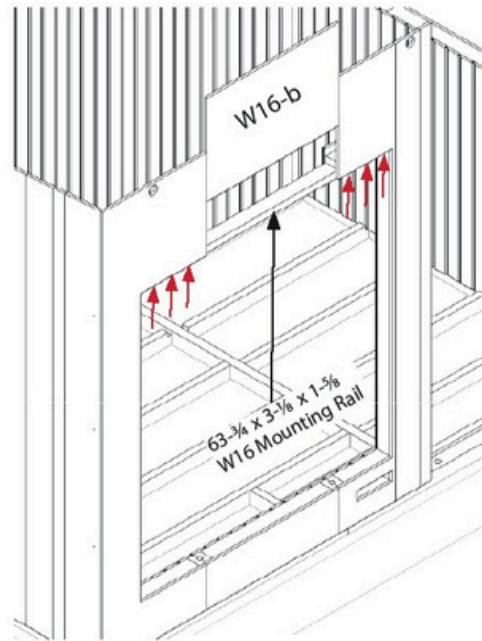

Image 15

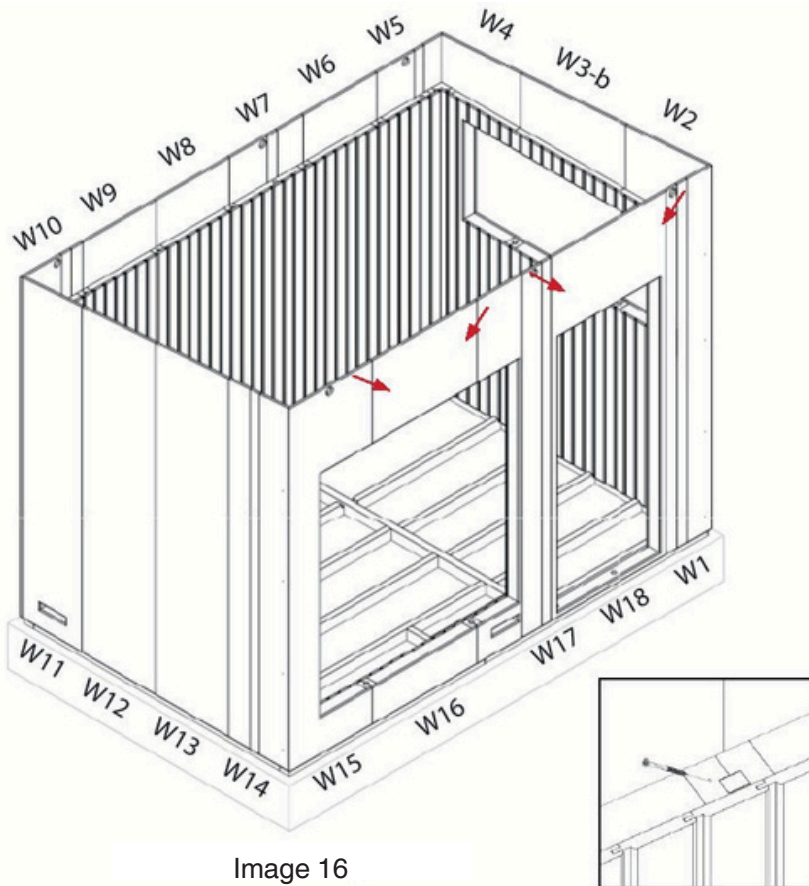

Image 16

PARTITION WALL ASSEMBLY

Locate the rear mounting rail and fasten it to wall W7 using four 5 X 80 screws; ensure the mounting rail is centered over the middle floor frame (17). Place wall W19 onto the middle floor frame with the multiclips exposed and fasten to the mounting rail at the top, and the floor frame at the bottom using two 5 X 70 screws (18).

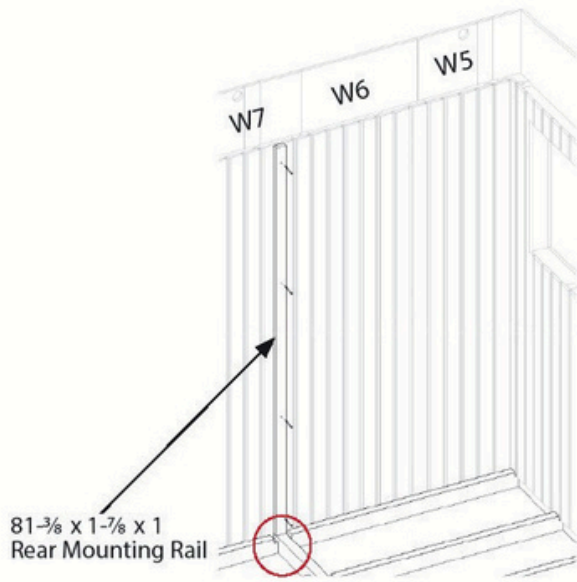

Image 17

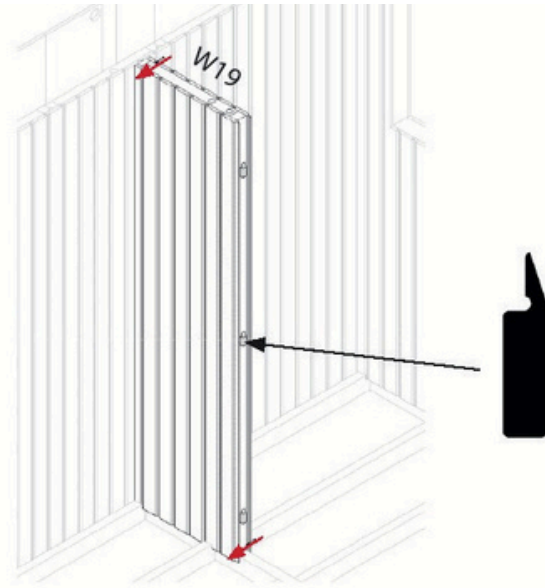

Image 18

FLOOR INSTALLATION

Starting with the partition wall floor board (54-3/4 x 4-1/2 x 3/4), lay it over the middle base frame and fasten through the tongue using four 3.2 X 40 screws on each side (19). Ensure the screws are countersunk so the next floor board does not have interference issues. Continue by placing long floor boards (76-3/4 x 4-1/8 x 3/4) groove over the tongue of the previous board, on either side of the partition floor board. Fasten using six 3.2 X 40 screws to connect the floor board to the base frames (20). Once you get to the last board on both sides, you may need to cut the boards width to fit the gap. Fasten down through the top of the floor board at the edge into the base frames using six 3.2 X 40 screws (21).

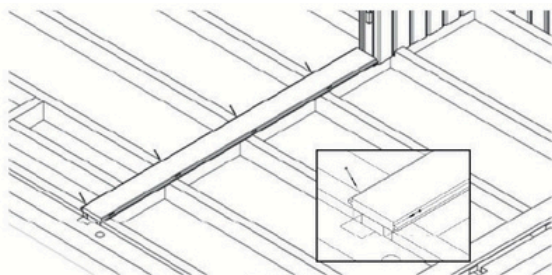

Image 19

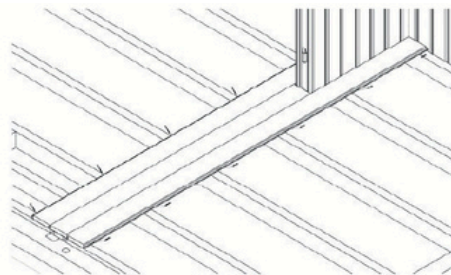

Image 20

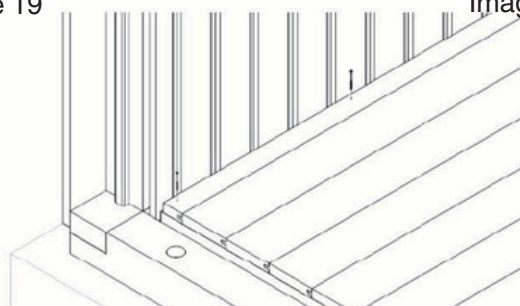
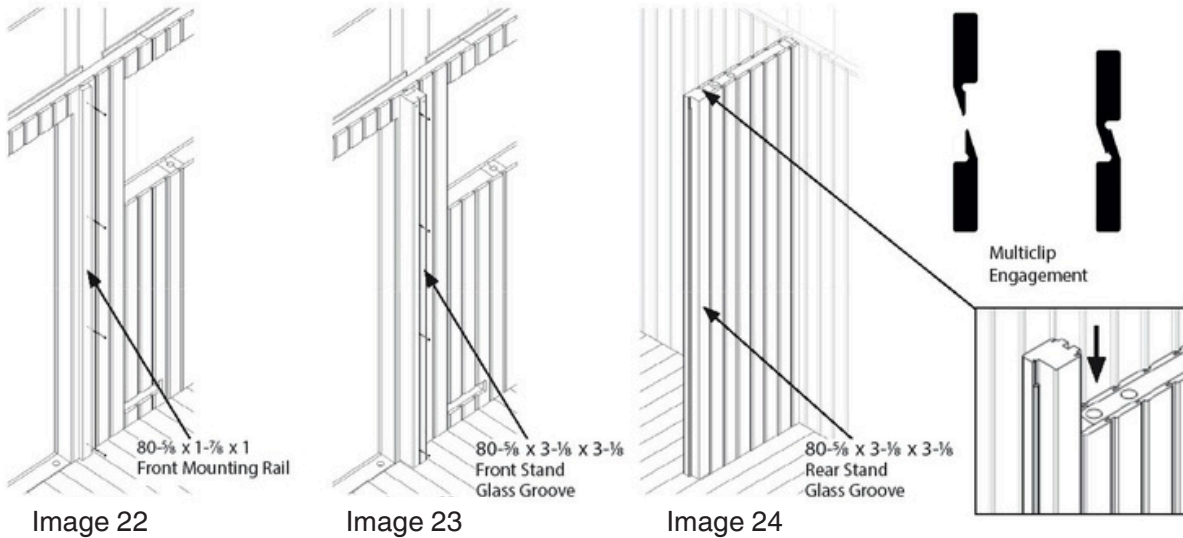

Image 21

PARTITION INSTALLATION

Locate the front mounting rail and fasten it to wall W17 using four 5 X 80 screws; ensure the mounting rail is aligned with W19 (22). Then fasten the front stand with glass groove to the front mounting rail using four 3.5 X 50 screws (23). Locate the rear stand with glass groove and slide it down over the multiclips to connect it to W19 (24).



NOTICE

- Handle glass with care. Do not allow glass to bend, and protect the corners to prevent it from shattering.

slide the glass and U-Channel into the front stand glass groove (25). Place the above door element over the glass and between both front/rear glass groove, predrill and fasten to the glass groove boards using four 4 X 70 screws (26). Insert the spacer bar into the above door element groove on the right side where the glass is not, and fasten through the bottom using three 3.2 X 40 screws (27).

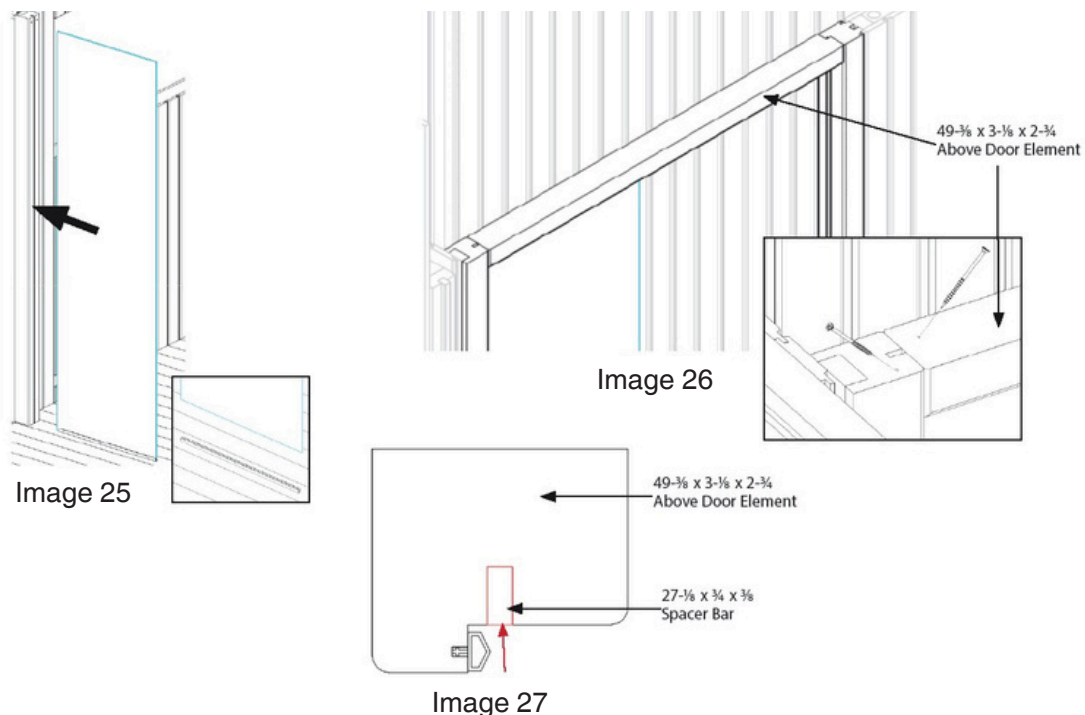

ELECTRICAL CABLE INSTALLATION

Decide where you would like your light located; it must be in a corner with a wall that has a cable channel in it. Wall 1, 5, 7, 10, 14 are the walls with cable channels. Drill a hole through the wall to access the cable channel to route the wire, then fasten the light to the wall (28-29). Ensure the light isn't against the ceiling, so there is room to install the corner cover strips. If using the lamp protection grille, it must be in the corner so it can span the corners and fasten using four 3.5 X 40 screws (30). It's easiest to hold off on installing the grille until after the corner covers are installed.



Image 28



Image 29



Image 30



DANGER

- Turn off power to heater at breaker before beginning installation or performing maintenance on the heater.

For the heater, use the cable channels in wall W17 to run the wires for the heater and temperature sensor (if required). You can run them up into the ceiling and then down another cable channel, and exit to the outside closest to the location of your incoming power. The cable channels can also be used to run the wires if your heater uses a digital controller. This step could be done once the inside ceiling is in place, but it is easiest to be able to locate and drill into the cable channels. When installing the ceiling in the next steps, make sure the components are placed correctly with the notches and cutouts so they don't interfere with your wire paths.

There are exterior wall components that fasten to the outside of the sauna. We would recommend not connecting the heater to incoming power until during or after that step to see the optimal location and method of connection.

See the Heater section later in this manual for more information about the heater installation.

ROOF INSTALLATION

Gather the six roof support strips and fasten on top of the walls using three 5 X 70 screws in each short strip and four in the long strips (31). Ensure the notches for the cables are oriented correctly.

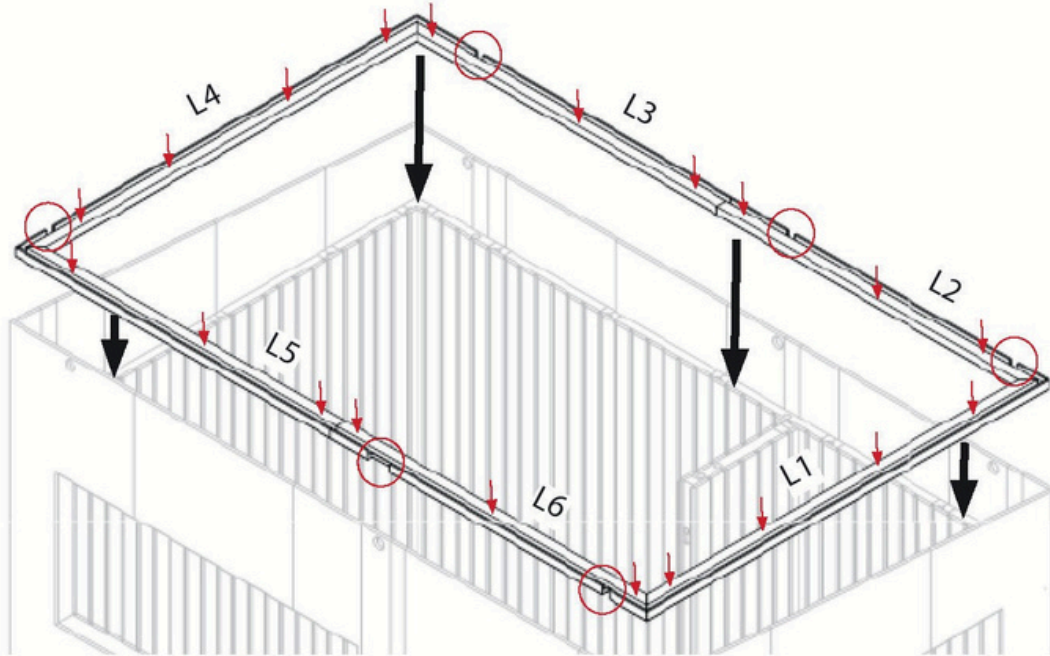

Image 31

Lay the six roof elements onto the roof support strips, and fasten using twenty-six 6 X 120 screws (32). Ensure the inspection opening and cable holes are oriented correctly.

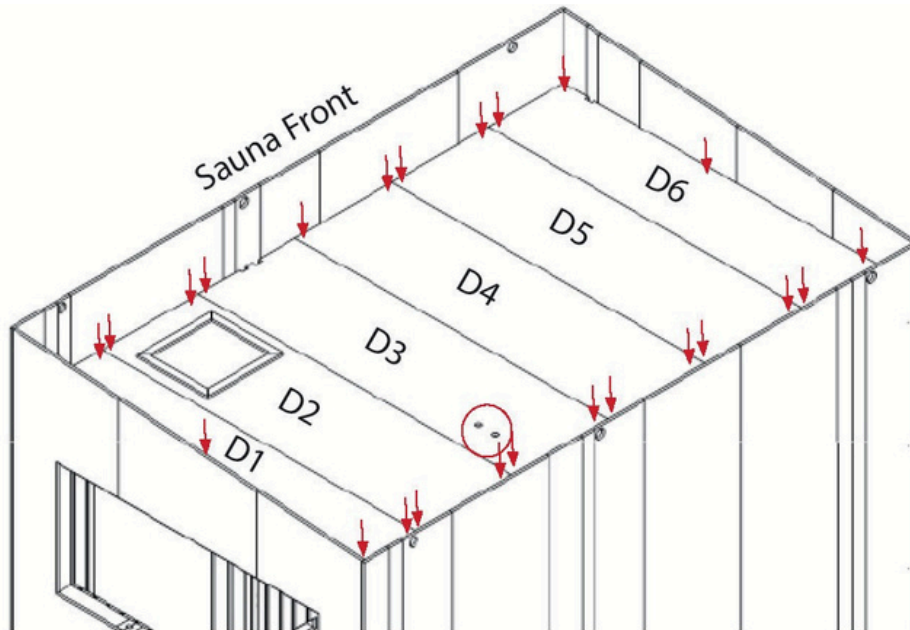

Image 32

This product manufactured by

ALMOST HEAVEN
SAUNAS

In the front of the roof, install the first layer of 4-5/8" roof rafter supports using seven 6 X 200 screws (33). Ensure the cutouts are correctly oriented. Repeat for the second layer of 4-5/8" roof rafter supports using seven 6 X 200 screws (34). The final height of the front roof rafter supports should be 9-3/8." In the back, use the single 3-1/8" tall roof rafter support and fasten using seven 6 X 200 screws (35).

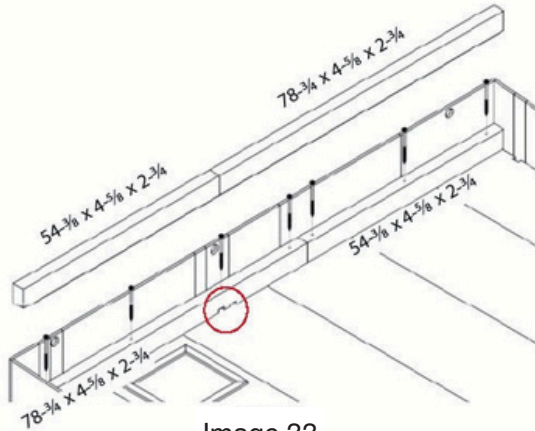

Image 33

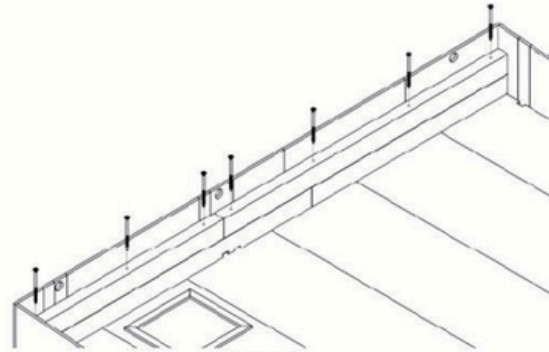

Image 34

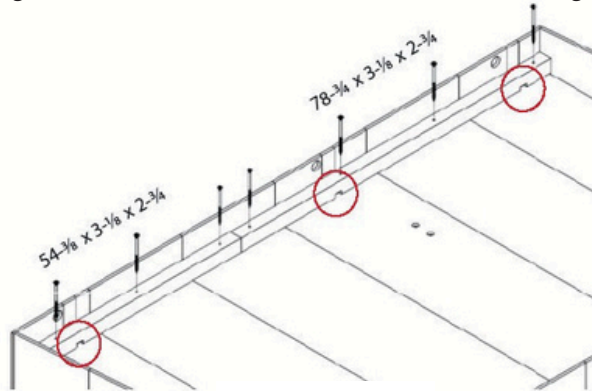

Image 35

Set the seven roof rafters (84-7/8 x 5-1/2 x 2-3/4) onto the rafter support rails 19" apart. Ensure the ends of the rafters sit flat on the support rails, the fasten them to the support rails using one 6 X 250 screw into each end (36).

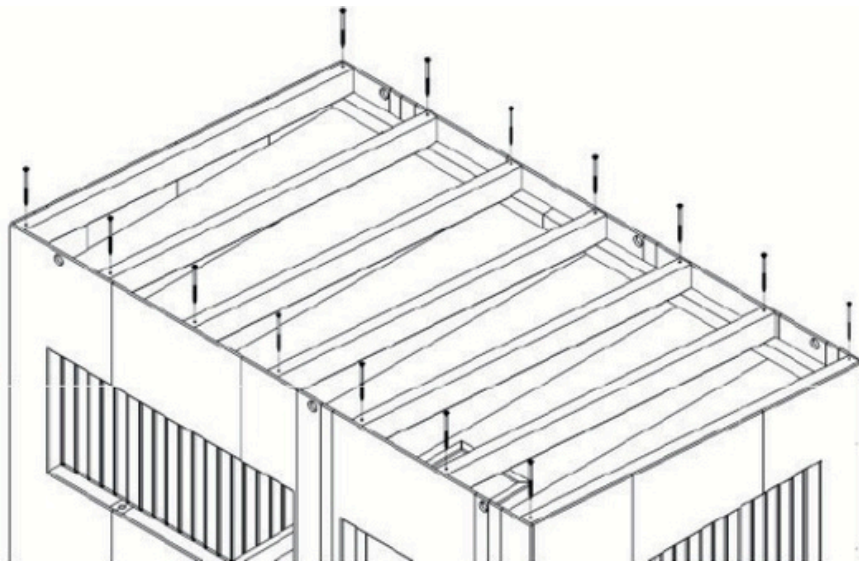

Image 36

Place the 4 roof panels (69-1/8 x 45 x 3/4) on top of the rafters and fasten using eighty 4 X 50 screws. Fasten the screws into the rafters, 5 per rafter per panel (37-38). Place the sheets of roofing felt over the roof panels using a 22-1/2" overlap, and attach using 150 roofing nails (39). We recommend 13 rows of nails, two in each row for the 3 lower sheets; then 4 in the last top sheet.

NOTICE

- We recommend purchasing shingles, metal roofing, or another suitable roof covering from your local

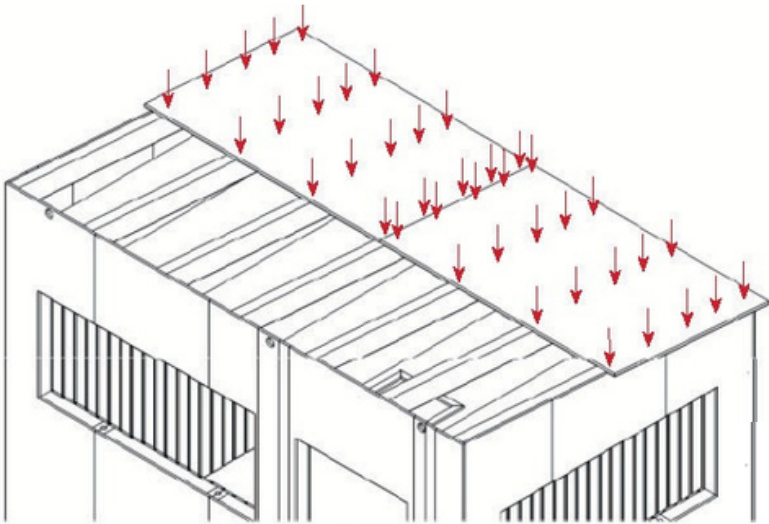

Image 37

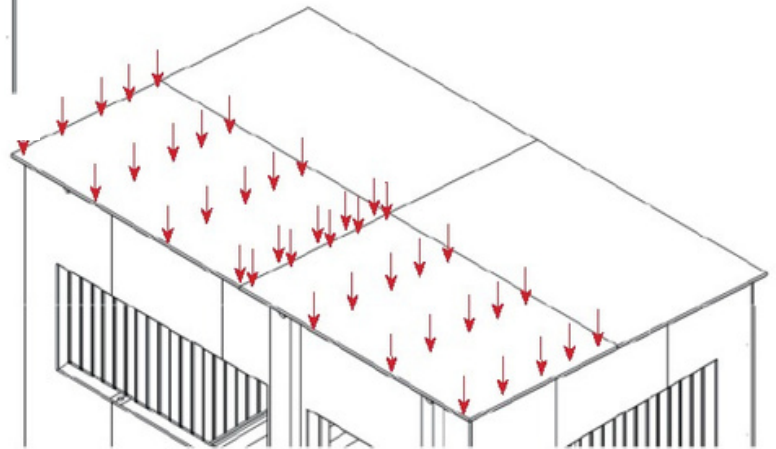

Image 38

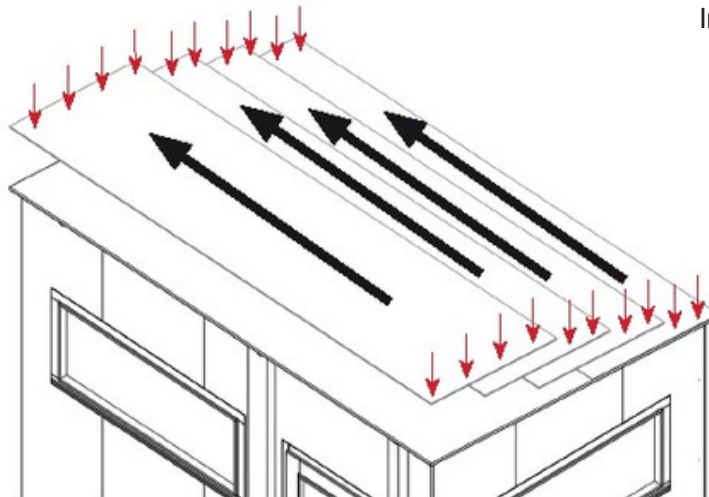

Image 39

Insert the 6 stainless steel ventilation covers into the outside of walls W1, W5, W7, W10, W15, W17 (40).

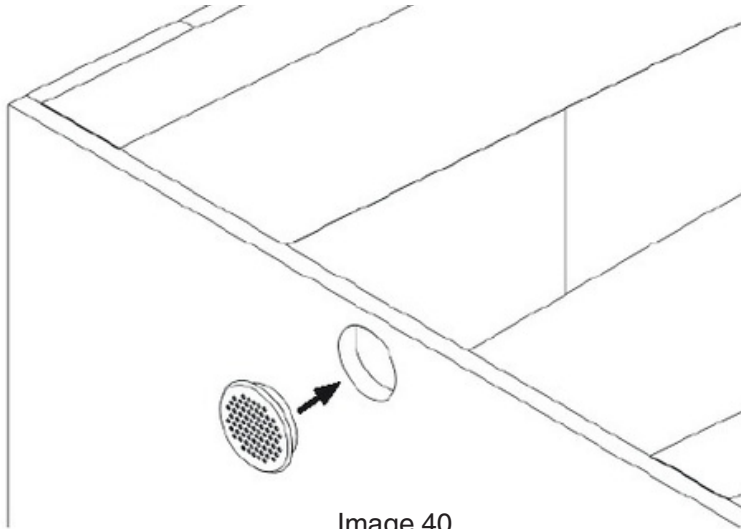

Image 40

WINDOW & DOOR INSTALLATION

Place the window mounting rails into the side window, offset in the opening to the inside of the sauna, and fasten using ten 4 X 70 screws in each window (41-42). Install the window from outside the sauna. Predrill through the window mounting rails and fasten through the mounting rails into the window frame using ten 5 X 80 screws for each window (43-44).

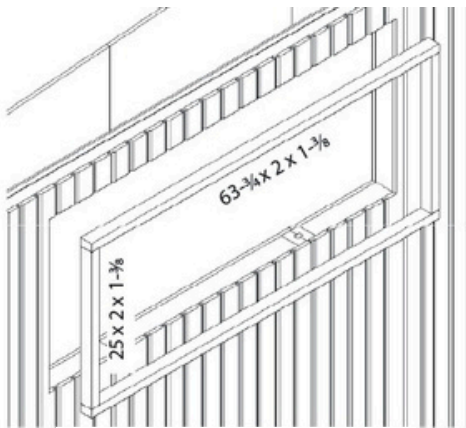

Image 41

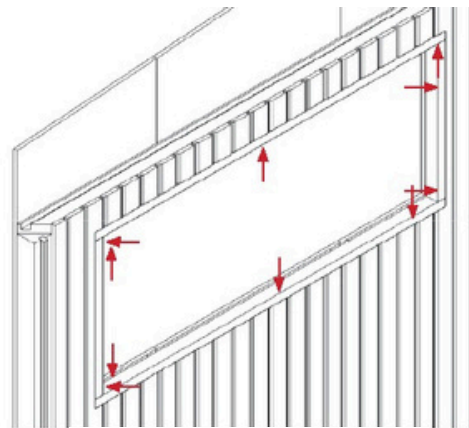

Image 42

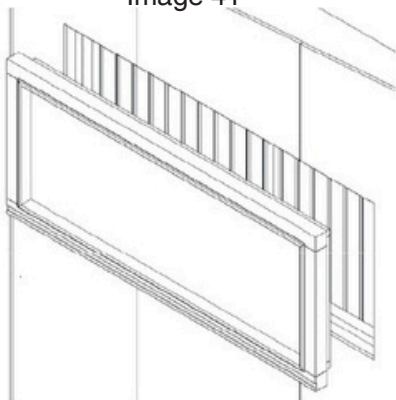

Image 43

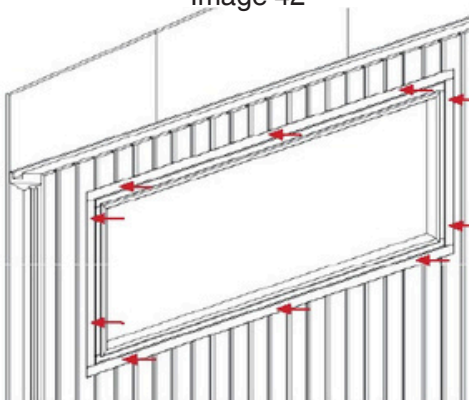
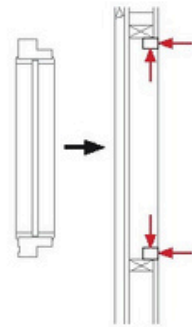

Image 44



Cover the window opening with the inner window frame, and fasten using fourteen 3.2 X 40 screws in each window (45).

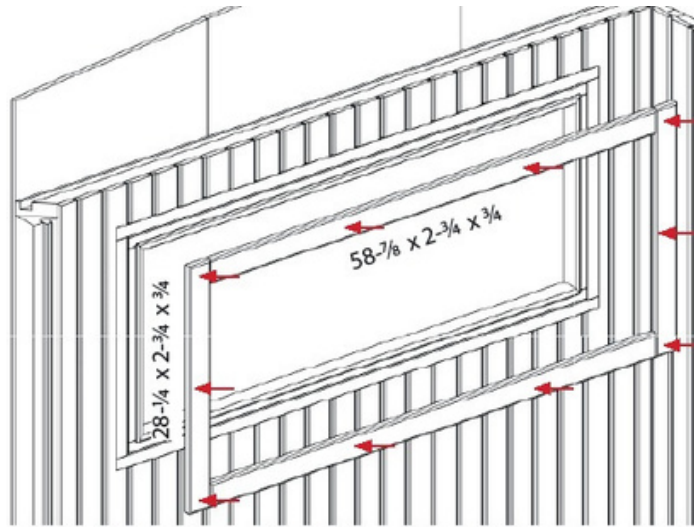

Image 45

Place the window mounting rails into the front window, offset in the opening to the inside of the sauna, and fasten using fourteen 4 X 70 screws in each window (46-47). Install the window from outside the sauna. Predrill through the window mounting rails and fasten through the mounting rails into the window frame using ten 5 X 80 screws for each window (48-49).

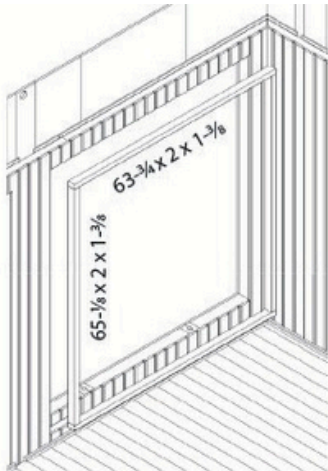

Image 46

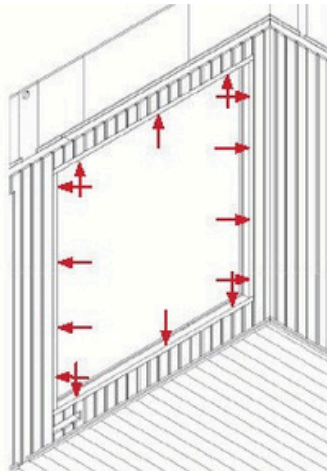

Image 47

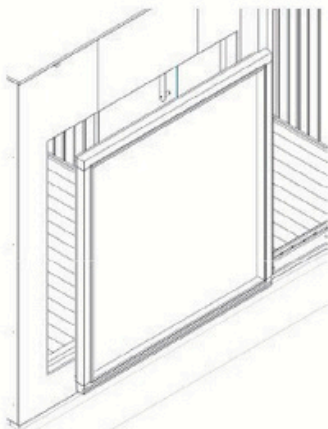

Image 48

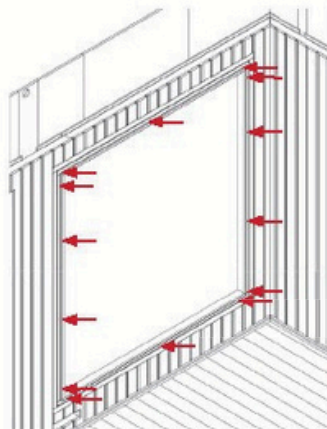

Image 49

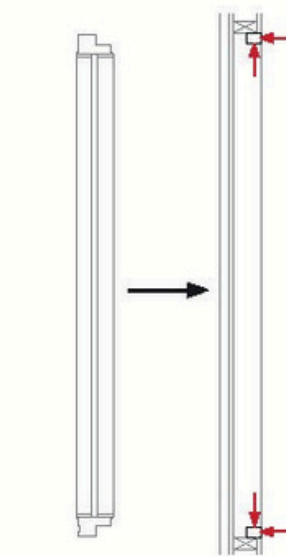

Image 61

Cover the window opening with the inner window frame, and fasten using fourteen 3.2 X 40 screws in each window (50).

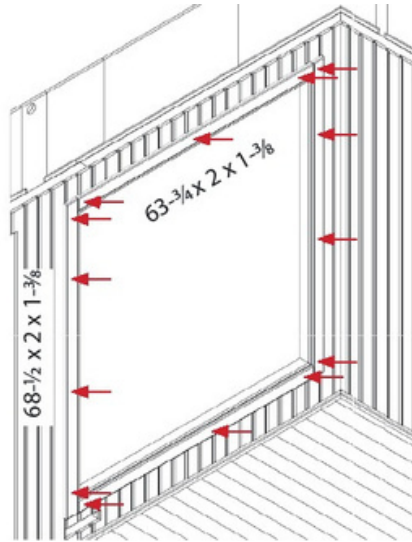

Image 50

Install the door handles onto the door (51). Place the door mounting rails into the door opening, offset in the opening to the inside of the sauna, and fasten using ten 4 X 70 screws (52-53). Set the door in the opening from the outside, pre-drill and fasten through the mounting rail using ten 5 X 80 screws (54-55). Cover the door opening with the inside door cover strips and fasten using thirteen 3.2 X 40 screws (56).

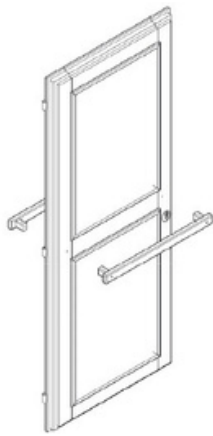

Image 51

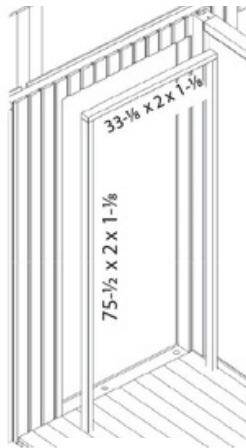

Image 52

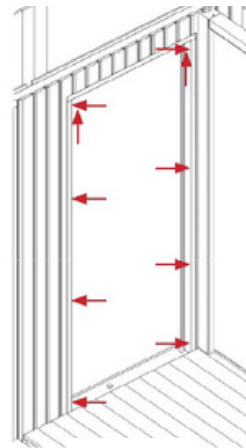

Image 53

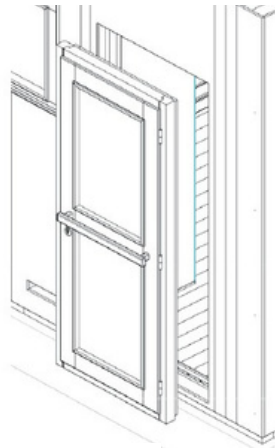

Image 54

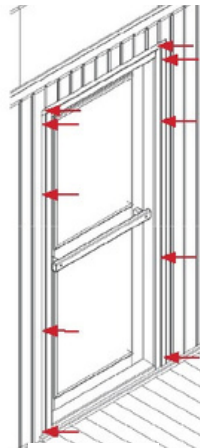

Image 55

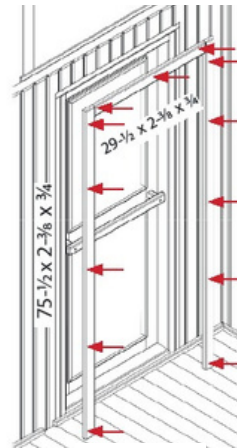

Image 56

BENCHES, BACKRESTS & OTHER INTERIOR COMPONENT INSTALLATIONS

Fasten the skirting boards around the base of the floor using twenty-six 3.2 X 40 screws (57). Install the ventilation slides over both exhaust openings using four 3.5 X 40 screws for each (58).

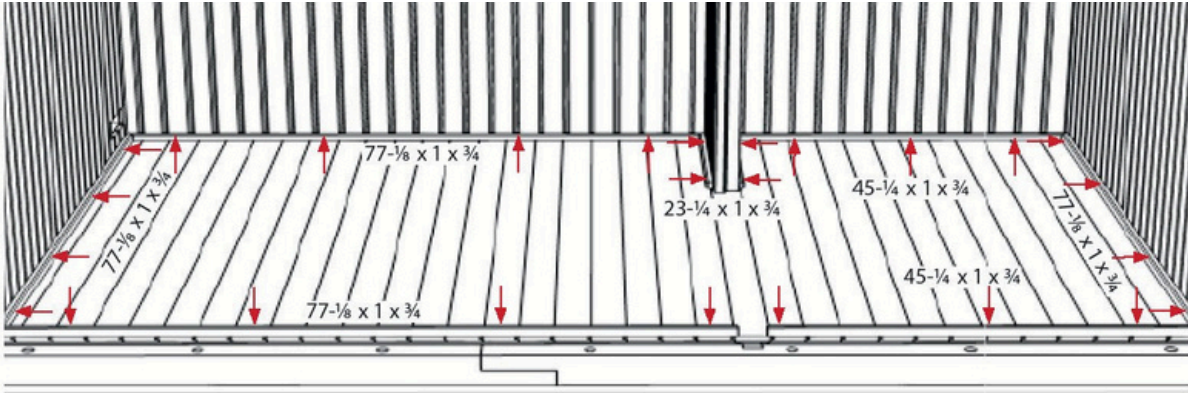

Image 57

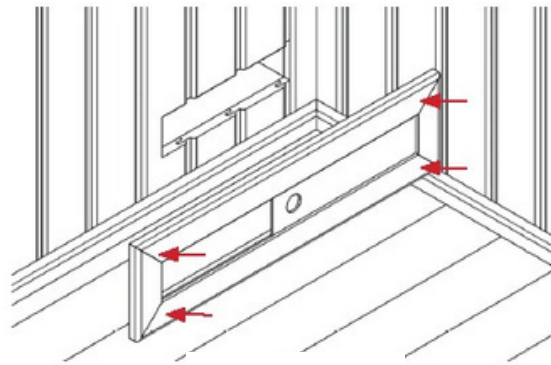

Image 58

NOTICE

- ALL SCREWS MUST BE PREDRILLED BEFORE INSTALLING TO PREVENT BREAKAGE.

Position the bench foot wall in front of W15, and fasten it to W14 using three 5 X 120 screws. It should be roughly 70-7/8" from the back wall to the bench foot wall; the feet also adjust if required. Mount the five 22-7/8 x 1-5/8 x 1-5/8 bench braces by predrilling and using three 5 X 70 screws in each to connect to the wall. Also, the two 47-1/4 x 1-5/8 x 1-5/8 bench braces by predrilling and using three 5 X 70 screws to connect to the wall. Fasten the two 10-1/4 x 1-5/8 x 1-5/8 bench screen mounting slats using two 4 X 60 screws in each (59).

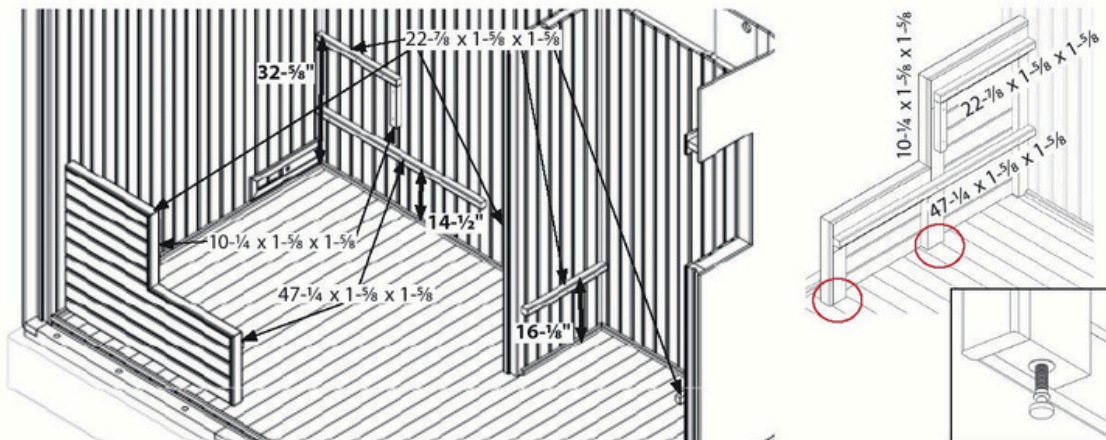

Image 59

Place a 70-1/2" bench on the left wall of the sauna, then place the 52-1/2" upper bench on the back wall and screw it into the face of the left bench using three 5 X 70 screws (60). Place the bench screen against the bench screen mounting slats and screw from the back using four 3.5 X 50 screws. Then place the remaining 70-1/2" bench on the lower supports. Lastly, place the 44-7/8" bench on the supports in the entrance area (61). For the backrest, you can set at a height of your choosing, but we recommend approximately 8" above the top bench. Fasten to the wall using three 3.5 X 40 screws in each back rest (62).

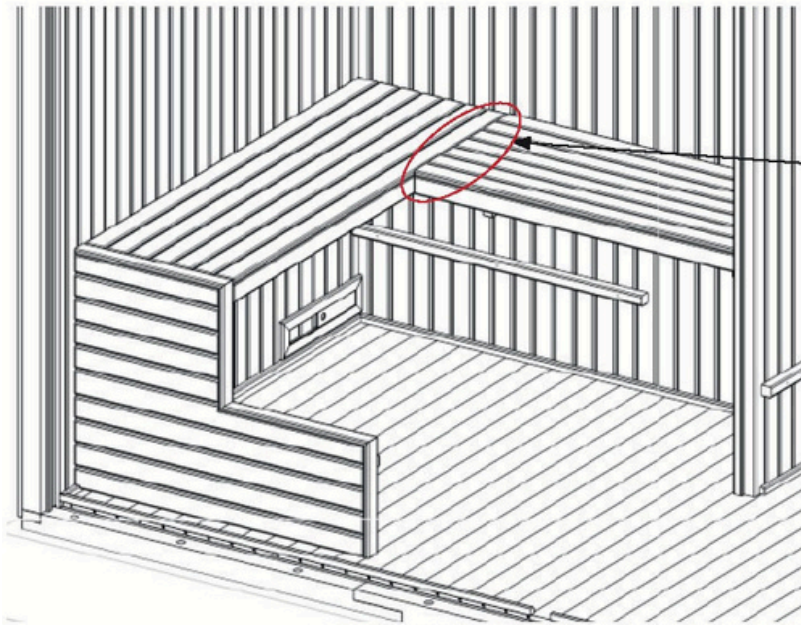

Image 60

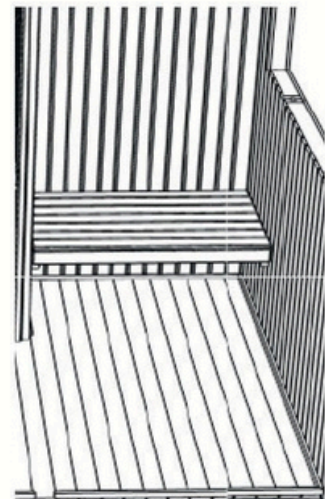
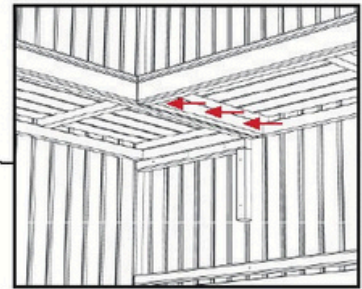

Image 61

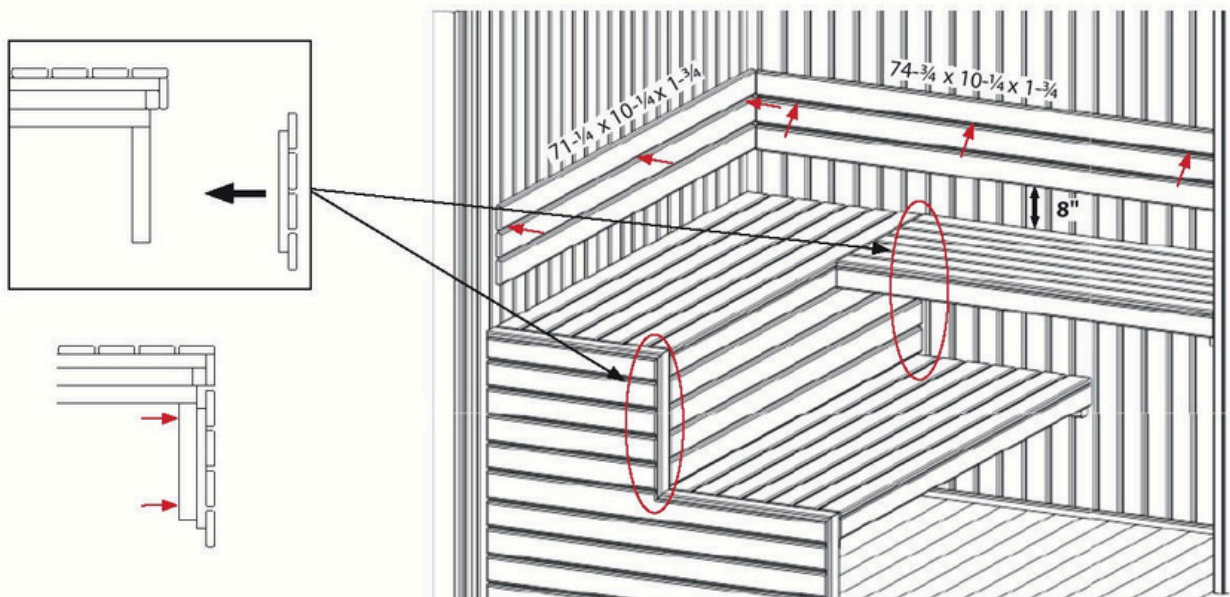

Image 62

Use the corner cover strips to conceal the vertical wall joints and ceiling joints; measure and cut to required length. Then fasten them to the wall using three to five 3.2 X 40 screws per strip depending on length, but no more than seventy (63).

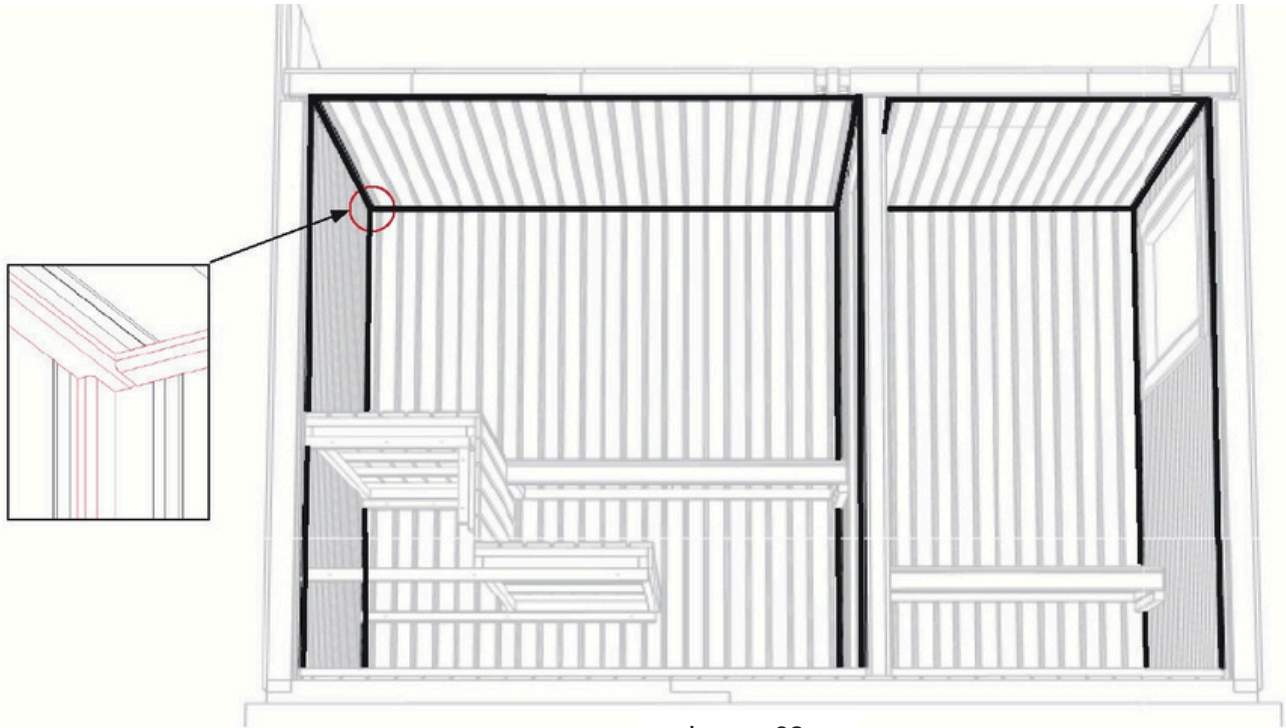

Image 63

EXTERIOR DECOR INSTALLATION

Fasten the outer ventilation grill over the outside openings in the sauna using four 3.5 X 40 screws in each. Install the exterior decor starting with element D1. Place the panels 2-1/2" off the foundation, and fasten using five rows of three 4.2 X 70 screws (64). **Note:** Panorama model is shown in 64-65, but View model installs the same way.

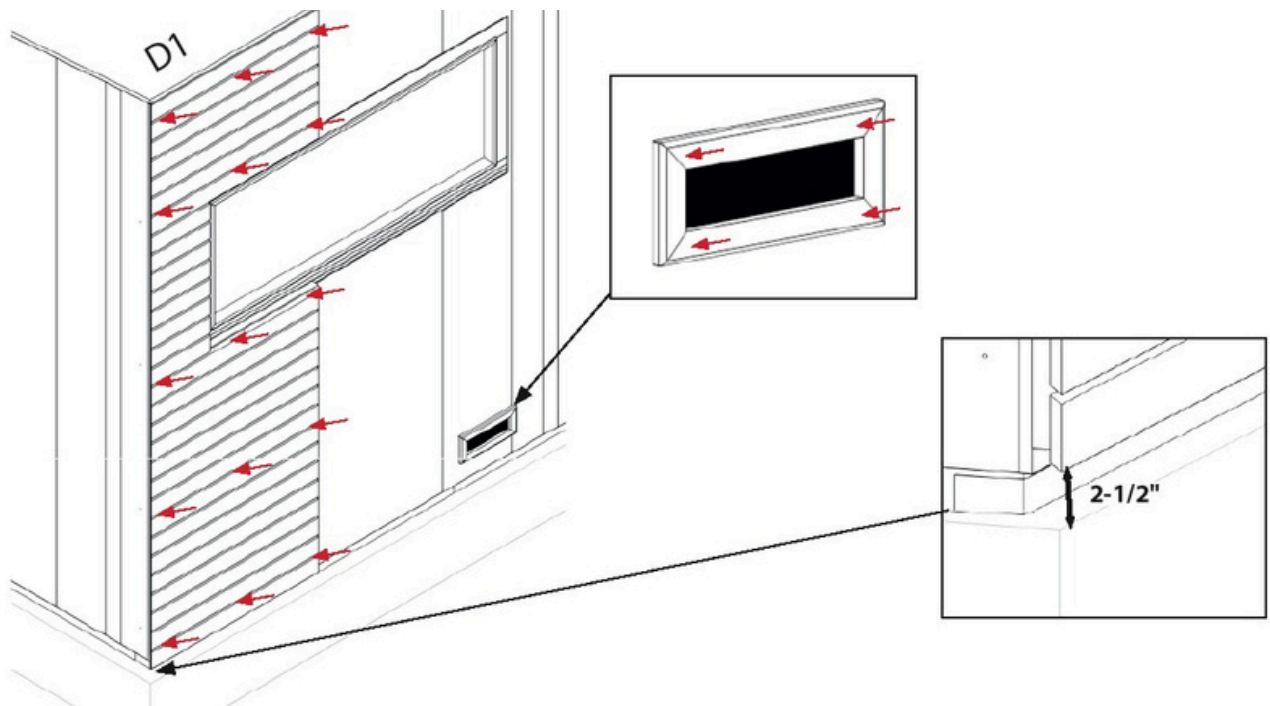

Image 64

Work around the front and right sides placing the exterior decor panels finishing with D7. In narrow sections, rows may only fit two 4.2 X 70 screws (65-66).

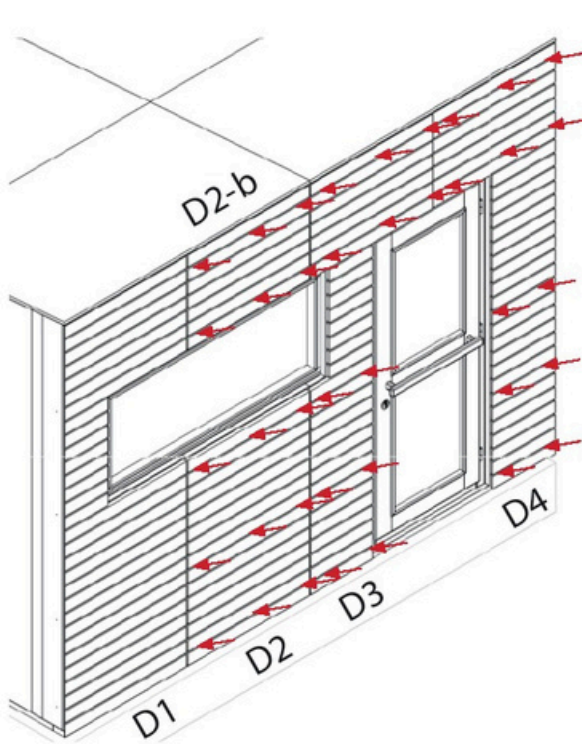

Image 65

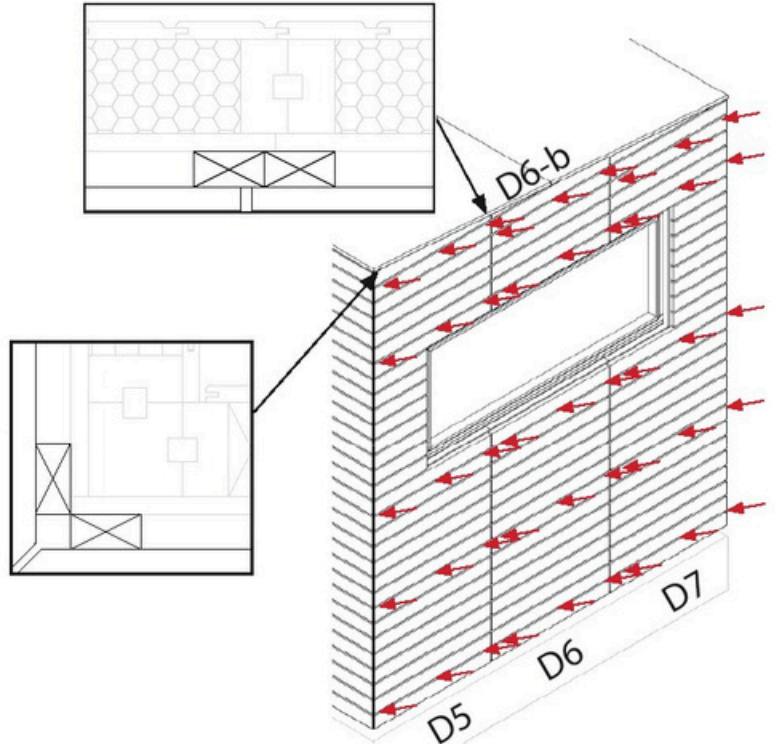

Image 66

Continue working around the sauna back and left side placing the exterior decor panels finishing with D14. In narrow sections, rows may only fit two 4.2 X 70 screws (67).

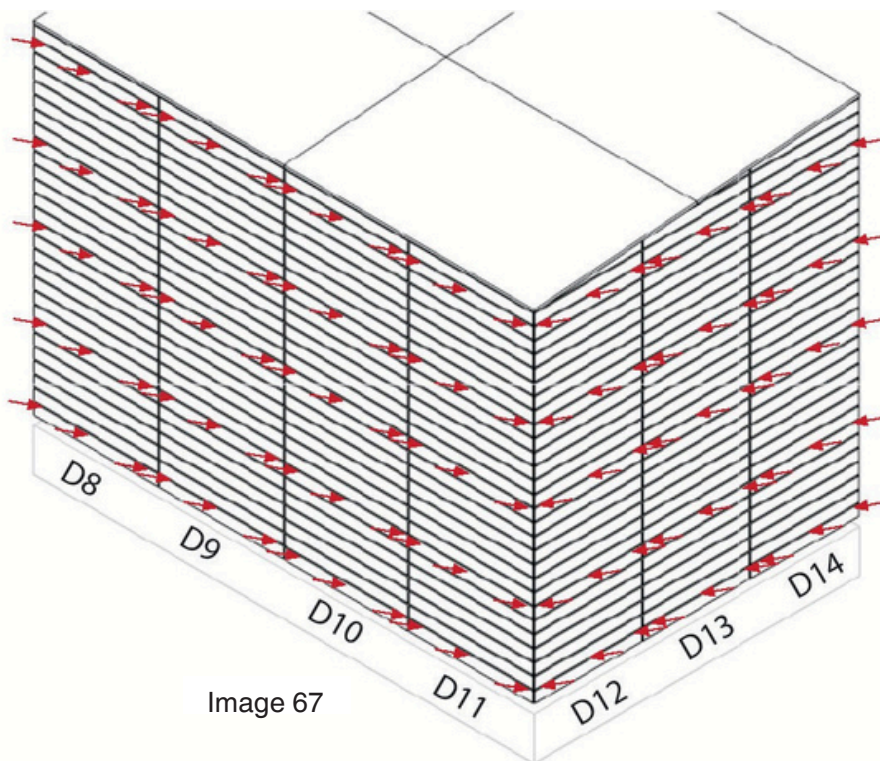

Image 67

Place the outer window frames over the side window using twelve 3.2 X 40 screws in the side window (68). Repeat for the front window using fourteen 3.2 X 40 screws (69). Fasten the outer mounting rail using three 3.2 X 60 screws below the door through the front, then place the outer door cover strips and fasten using fourteen 3.2 X 40 screws, and (70) The bottom cover strip will rest on the mounting rail and fasten into it.

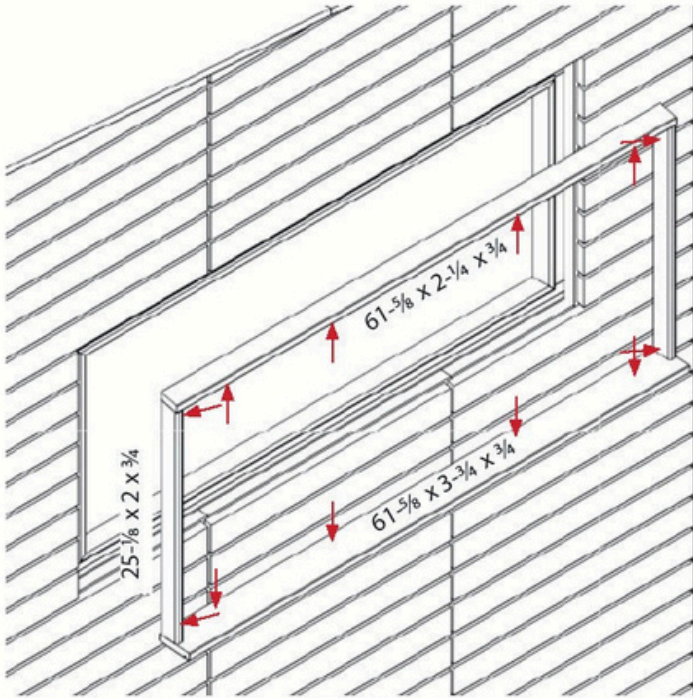

Image 68

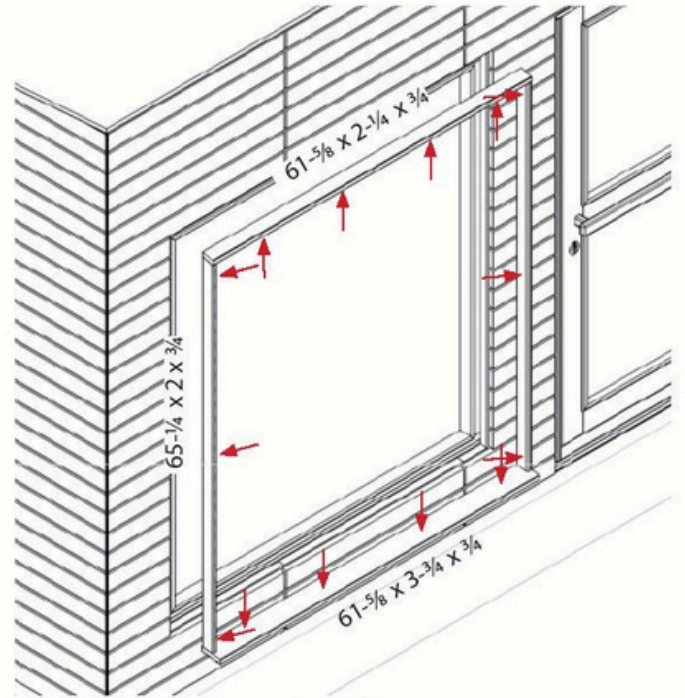

Image 69

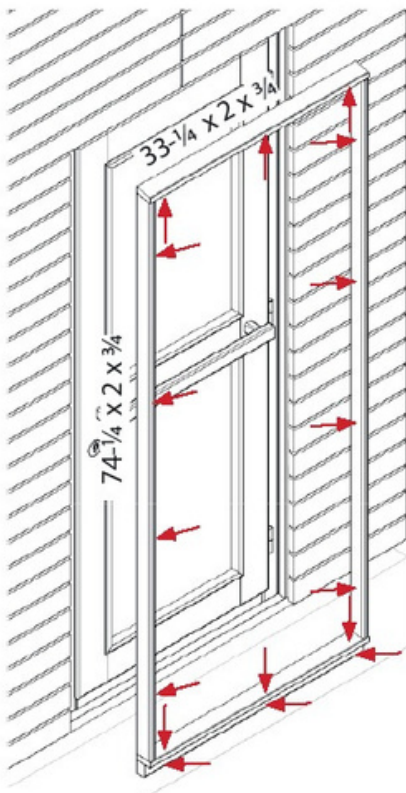

Image 70

This product manufactured by

ALMOST HEAVEN
SAUNAS

INTERIOR DOOR INSTALLATION

Connect the hinges to the interior door, ensuring they are fastened so the door swings into the entrance room (71). The bottom door handle hole is 36-3/8" from the bottom. Make sure the hinges are straight, and then mount the door to the rear stand glass groove using three 4 X 30 screws (72-73). Rotate the plastic spacers on the hinges if the hinges are not perfectly straight. Install the door handle with the wooden handle inside the sauna (74). Install the push plate over the top of the glass (75). Then install the door magnet into the door frame so it matches the push plate location..



Image 71

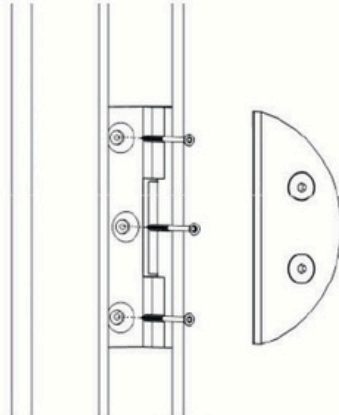

Image 72

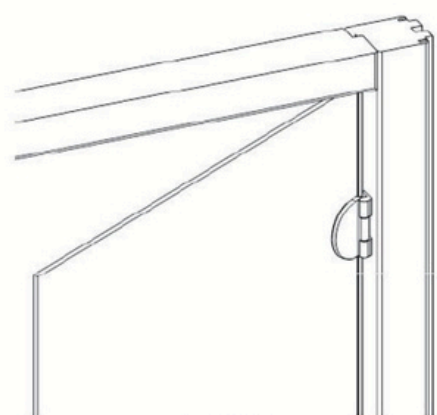

Image 73

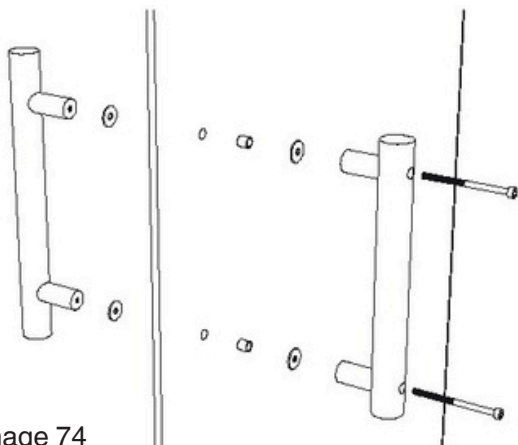

Image 74

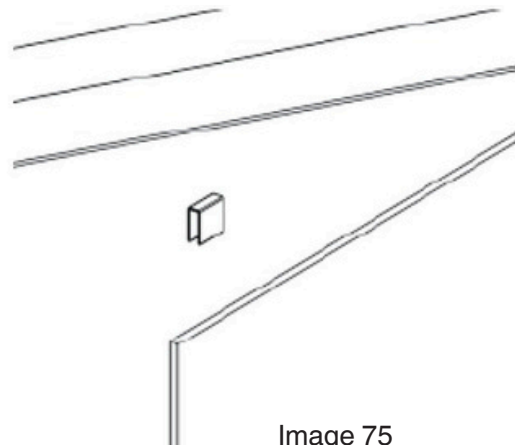
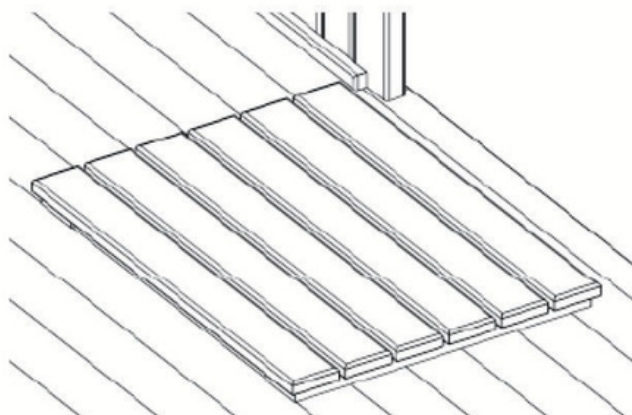

Image 75

Your sauna also comes with 2 head rests and 1 floor grid. We recommend placing the floor grid in the entrance room outside the sauna room to wipe your feet before entering the sauna (76).

Image 76



HEATER - Please see heater manual.

 **DANGER**

- Turn off power to heater at breaker before beginning installation or performing maintenance on the heater
Failure to turn off the power will lead to electrocution and even death.

 **CAUTION**

- Improper installation of heater or heater mounting bracket could cause the heater to fall leading to burns and other injuries.
- Before placing or adjusting stones, ensure heater is back to room temperature. Failure to do so may cause burns.

FINAL THINGS

Once assembly is complete, sweep and vacuum the inside of the sauna. Wipe down the entire interior with a damp cloth to remove any remaining dirt, dust and debris.

Note: If the sauna has absorbed moisture in storage, the staves may shrink as the high heat evaporates that moisture. This may require you to tighten the band even further. If your sauna is left in the open rain, this will cause the staves to expand again resulting in an event tight seal.

The wood of the outdoor sauna is untreated. To increase the durability of the wood, we recommend treating the outside only with an exterior grade stain or sealant of your choice. This will help to protect the wood from excess moisture.

TRADITIONAL SAUNA USE

Congratulations! You are ready to enjoy your barrel sauna! You may use your sauna in a wet or dry fashion. Dry, meaning you do not sprinkle any water onto the stones; wet, meaning you increase the humidity of the room by sprinkling water on the stones. Please note, not much water is needed to achieve a wet sauna experience. The sauna as we know it originates in Finland. The typical sauna experience follows the steps below, but you may enjoy your sauna in any way you like!

- Set your heaters so your sauna achieves the desired temperature. This is typically 160-185+ degrees F. Novice sauna users should begin at the lower end of that range and increase their high temperature over time.
- Take a quick shower or a quick dip in a hot tub or pool.
- Step into the sauna and enjoy for 5-15 minutes, bringing a towel to sit or lay on. Leave the sauna once you are perspiring freely.
- Take a plunge in a pool, shower, snowbank, lake-anything that will cool you down! After that, relax and cool down for 10-20 minutes.
- Step into the sauna again. During this visit, you may wish to sprinkle a small amount of water onto the stones to create bursts of steam. If water spills through the heater to the floor, you are using too much water, though this will not hurt the heater or the sauna.
- Continue repeating this process. After your final visit to your sauna, relax for at least 20 minutes. Shower with warm water initially, finishing with cool water to close your skin pores.
- Prepare to feel refreshed for the day or to have an amazing night's sleep!

Whatever your sauna routine, it is imperative that you **STAY HYDRATED!**

This product manufactured by

ALMOST HEAVEN
SAUNAS



CARE & MAINTENANCE

TREATING LUMBER

The lumber we use is naturally resistant to the elements. Left untreated, the exterior of the sauna will weather naturally, and that's fine. At any point in the future you can pressure wash (low pressure only) your sauna to bring back most of the original color.

If you wish to retain the natural color of the lumber, your local paint store can recommend a suitable exterior stain. Be sure that it has a UV inhibitor so that it will best resist the effects of sunlight. Follow the manufacturer's instructions for application. NEVER TREAT THE INTERIOR OF THE SAUNA UNLESS APPROVED FOR USE IN A SAUNA, AND NEVER USE VARNISH OR PAINT ON THE EXTERIOR.

CLEANING THE LUMBER

You should vacuum or brush out your sauna periodically to remove loose dirt. Over time the floor and seats of your sauna may discolor due to perspiration, dirt and general wear. You can remove dirt or stains with a solution of baking soda and water, lightly scrubbing the wood with the solution and then rinsing. Heavier stains or scuffs can be sanded out with fine grit sandpaper. Alternatively, pressure washing the interior of the sauna with a low-pressure, wide pattern nozzle will remove stains and dirt very effectively.

LOCATION AND GEOGRAPHY

Climate and temperature affect the lumber in different ways and to varying degrees. The effects of swelling and contraction as well as fading from sunlight will vary depending on the intensity of the sun and the levels of humidity and amounts of moisture in your area. The degree of these effects will not affect the quality or performance of your sauna, but may require you to tighten bands or re-stain your sauna more or less frequently. It is a good idea to check the tension of your bands and examine the degree of fading every few months, especially in the first months of owning your sauna so that you can respond accordingly.

REPLACEMENT OF SAUNA STONES

Over time your sauna stones may crack and split due to the fluctuations in temperature the stones experience. If you ever need to replace stones, only use sauna stones designed for use in your sauna heater. You can purchase replacement stones from RateOutdoors Saunas at any time.

REPLACEMENT PARTS

If you ever damage the exterior of the sauna, you can purchase replacement staves, doors, and components from Almost Heaven Saunas at any time.

ACCESSORIES

Almost Heaven Saunas offers a full line of accessories to compliment your sauna. From red cedar leg rests, back rests, drink holders, robe hooks and magazine racks to eucalyptus fragrance and more, visit support@rateoutdoors.com for all of your sauna accessory needs!

This product manufactured by

ALMOST HEAVEN
SAUNAS