

INSTALLATION & OWNER'S MANUAL

The ALPINA MEDIUM - VIEW SAUNA

Read these instructions to guide your assembly.



It is highly recommended to view the assembly video prior to starting assembly!

This product manufactured by

ALMOST HEAVEN
SAUNAS





IMPORTANT SAFETY INSTRUCTIONS

DANGER:Indicates a hazardous situation that, if not avoided, will result in death or serious injury.

WARNING:Indicates a hazardous situation that, if not avoided, could result in death or serious injury.

CAUTION:Indicates a hazardous situation that, if not avoided, could result in minor or moderate injury.

NOTICE:Indicates information considered important, but not hazard-related.

-  **READ ALL INSTRUCTIONS BEFORE INSTALLATION AND USE TO AVOID INJURY OR DAMAGE TO SAUNA**
-  **FOLLOW SAFETY INFORMATION IN THIS DOCUMENT TO AVOID SERIOUS INJURY OR DEATH**
-  **REFER TO YOUR LOCAL BUILDING CODES FOR ANY SPECIFIC INSTALLATION REQUIREMENTS**
-  **ALL ELECTRICAL WORK NEEDS TO BE COMPLETED BY A LICENSED ELECTRICIAN. FAILURE TO DO SO COULD CAUSE INJURY OR DAMAGE TO THE HEATER.**
-  **KEEP THESE INSTRUCTIONS FOR FUTURE REFERENCE**

WARNING

- This sauna is not intended for use by persons (including children) with reduced physical, sensory or mental capabilities, or lack of experience and knowledge, unless they have been given supervision or instruction concerning use of the sauna by a person responsible for their safety.
- Consult your doctor about any health-related limitations related to sauna use. Ignoring advice from your medical provider could cause serious injury or death.
- Do not let people with pre-existing health conditions bathe in the sauna on their own. Using the sauna could cause these users to lose consciousness.
- Parents should consult your pediatrician before allowing children to use the sauna. Ignoring advice from your medical provider could cause serious injury or death.
- Do not smoke, use alcohol, or exercise in the sauna. These tasks could cause users to lose consciousness.
- Do not exceed 30 min. in the sauna at one time, as excessive exposure may be harmful to health.
The sauna should not be used as an endurance test.
- Do not place any combustible material over the sauna heater (towels, bathing suits, wooden bucket or ladle)!
This will cause the sauna to catch fire.
- Hyperthermia occurs when the internal temperature of the body reaches a level several degrees above the normal body temperature of 98,6 °F. The symptoms of hyperthermia include an increase in the internal temperature of the body, dizziness, lethargy, drowsiness, and fainting.
- Only use stones approved for sauna heater use. Inadequate stones may crack or explode leading to serious injury.

This product manufactured by

ALMOST HEAVEN
SAUNAS



- Do not sleep in a sauna that the heater is operating. Sleeping in a heated sauna may lead to injury or death.

CAUTION

- Keep all occupants away from the heater and when it is hot. The stones and outer surface of the heater may burn your skin.
- Do not throw excessive amounts of water on the stones. The evaporating water is boiling hot and could cause burns.
- Do not throw water directly onto the elements. This could cause burns and damage to the heater.
- Be very careful when moving in the sauna, as the benches and floors may be slippery. This could cause the user to slip and fall.
- Do not alter the sauna in any way, unless explicitly instructed in this manual. Altering the sauna could lead to structural damage, increasing the risk to bodily harm.
- When moving and lifting heavy pieces, use two or more people. Moving pieces without adequate manpower will lead to injury.

A WORD ABOUT OUR SAUNAS

This sauna kit is designed to be assembled by a general contractor or professional builder.

If you have any questions about assembly, please do not hesitate to call us at **773-435-7596**, or send us an email at support@rateoutdoors.com.

Thank you again for choosing Almost Heaven. We are grateful for your business and know you will have many years of enjoyment in your sauna!

Your Almost Heaven sauna is designed for outdoor use although it is perfectly fine to use it indoors. The lumber is naturally resistant to the elements. Rain and sun will not damage the wood, although natural weathering and coloring of the wood will occur over time. To preserve the initial look of the sauna, you may choose to stain the exterior with a UV inhibiting stain. Consult your local paint store for their recommendations on a particular stain for your sauna. We do not recommend that you paint or varnish inside your sauna. Properly assembled, you should not experience water dripping in the sauna.

LOCATING THE SAUNA

Because the traditional sauna experience involves a heating-cooling-resting regimen, it is important to plan ahead before installing your sauna. Our method of construction allows you to place your sauna in a wide variety of settings.

Be sure the surface is firm and level, and can support the weight of the sauna and its users (1,000+ lbs). A deck or concrete slab is certainly an option, but if your sauna sits directly on the ground, be sure the base boards sit on paver stones or something similar to prevent the sauna from settling into the ground.

This product manufactured by

ALMOST HEAVEN
SAUNAS



BASIC TOOLS

These tools are helpful in the assembly of your barrel sauna:

- Cordless Drill
- Drill Bit Set
- Bit Set
- Rubber Mallet
- Hammer
- Framing square
- 1/4" Hex Bit
- Utility knife
- Level
- Tape Measure
- Ladder

Table or Skill Saw

FIRST CONSIDERATIONS

Before beginning assembly, ensure that the installation surface is level. Many garage, basement or deck floors are sloped for drainage. A slight slope will not be an issue, but a more pronounced slope will require shimming to make the sauna level. An uneven installation surface can result in poor-fitting staves leading to poor sauna function. Also, if the site might receive heavy winds, it is recommended extra precautions are taken to ensure the door does not blow open. In most situations, this factor will not be a concern.

ELECTRICAL REQUIREMENTS

Costs of an electrician can vary greatly depending on several factors, including your sauna's distance from your electrical service box, where you live and cost of materials. We always recommend you get quotes from two to three different licensed electricians before you begin installation in order to get the best possible service and price.

Use copper wire with 90C insulation. Do not use aluminum wire to make the connection. Consult with an electrician so you can determine the requirements for your particular situation. All wiring must conform to all national, state and local codes and regulations.

For further information and instruction on your heater installation and operation, please consult the provided heater manual.

This product manufactured by

ALMOST HEAVEN
SAUNAS



PARTS LIST

No. of items	Name	Dimensions inches
Floor frame, outer		
1	Floor frame (impregnated) - left	84- ⁵ / ₈ x 3- ¹ / ₈ x 3- ¹ / ₈
1	Floor frame (impregnated) - right	84- ⁵ / ₈ x 3- ¹ / ₈ x 3- ¹ / ₈
1	Floor frame (impregnated) - front	84- ⁵ / ₈ x 3- ¹ / ₈ x 3- ¹ / ₈
1	Floor frame (impregnated) - rear	84- ⁵ / ₈ x 3- ¹ / ₈ x 3- ¹ / ₈
Floor frame, inner		
2	Base frame (impregnated)	78- ³ / ₈ x 3- ¹ / ₈ x 2- ³ / ₈
4	Base frame (impregnated)	80- ³ / ₄ x 3- ¹ / ₈ x 1- ⁵ / ₈
1	Base frame (impregnated)	13- ¹ / ₂ x 3- ¹ / ₈ x 1- ⁵ / ₈
1	Base frame (impregnated)	23- ⁵ / ₈ x 3- ¹ / ₈ x 1- ⁵ / ₈
22	Floor boards	76- ³ / ₄ x 4- ¹ / ₈ x ³ / ₄
4	Skirting board 2x45°	77- ¹ / ₈ x 1 x ³ / ₄
Wall elements		
1	Wall element W1 - Electrical element	95- ⁷ / ₈ x 22 x 4- ³ / ₈
1	Wall element W2	94 x 22- ¹ / ₈ x 4- ³ / ₈
1	Wall element W3	94 x 24- ³ / ₈ x 4- ³ / ₈
1	Wall element W4	94 x 24- ³ / ₈ x 4- ³ / ₈
1	Wall element W5 - Electrical element	94 x 19- ¹ / ₄ x 4- ³ / ₈
1	Wall element W6 - Ventilation element	95- ⁵ / ₈ x 20 x 4- ³ / ₈
1	Wall element W7	97- ³ / ₈ x 24- ³ / ₈ x 4- ³ / ₈
1	Wall element W8	99- ¹ / ₈ x 24- ³ / ₈ x 4- ³ / ₈
1	Wall element W9	100- ¹ / ₂ x 18- ³ / ₄ x 4- ³ / ₈
1	Wall element W10	100- ¹ / ₂ x 27- ¹ / ₄ x 4- ³ / ₈
1	Wall element W11	6- ⁵ / ₈ x 34- ³ / ₈ x 4- ³ / ₈
1	Wall element W11-b	22- ⁵ / ₈ x 33- ⁷ / ₈ x 4- ³ / ₈
1	Wall element W12	100- ¹ / ₂ x 26 x 4- ³ / ₈
1	Wall element W13 - Electrical/ventilation element	100- ¹ / ₂ x 23- ¹ / ₄ x 4- ³ / ₈
1	Wall element W14	98- ⁷ / ₈ x 41 x 4- ³ / ₈
1	Mounting rail W11	72 x 3- ¹ / ₈ x 1- ⁵ / ₈
Corner posts		
4	Corner posts	79- ⁷ / ₈ x 3- ¹ / ₈ x 3- ¹ / ₈
Ceiling		
1	Roof support strip L1	84- ⁵ / ₈ x 3- ¹ / ₈ x 1- ³ / ₈
1	Roof support strip L2	84- ⁵ / ₈ x 3- ¹ / ₈ x 1- ⁵ / ₈
1	Roof support strip L3	84- ⁵ / ₈ x 3- ¹ / ₈ x 1- ⁵ / ₈
1	Roof support strip L4	84- ⁵ / ₈ x 3- ¹ / ₈ x 1- ⁵ / ₈
1	Roof element D1	83- ⁷ / ₈ x 26- ¹ / ₄ x 3- ⁷ / ₈
1	Roof element D2	83- ⁷ / ₈ x 31 x 3- ⁷ / ₈
1	Roof element D3 - Inspection opening	83- ⁷ / ₈ x 28- ³ / ₈ x 3- ⁷ / ₈
Roof		
1	Rafter support (rear)	84- ⁵ / ₈ x 3- ¹ / ₈ x 2- ³ / ₄
1	Rafter support (front, bottom)	84- ⁵ / ₈ x 4- ⁵ / ₈ x 2- ³ / ₄
1	Rafter support (front, top)	84- ⁵ / ₈ x 4- ⁵ / ₈ x 2- ³ / ₄
5	Roof rafters	84- ⁷ / ₈ x 14 x 2- ³ / ₄
2	Roof panels	89- ³ / ₄ x 45 x ³ / ₄

No. of items	Name	Dimensions inches
Window		
2	Mounting rails	72 x 2 x 1- ³ / ₈
2	Mounting rails	68- ¹ / ₂ x 2 x 1- ³ / ₈
1	Window	72 x 70- ⁷ / ₈ x 4- ³ / ₈
2	Window frame - inner	67- ¹ / ₈ x 2- ³ / ₄ x ³ / ₄
2	Window frame - inner	71- ³ / ₄ x 2- ³ / ₄ x ³ / ₄
2	Window frame - outer	68- ⁵ / ₈ x 2 x ³ / ₄
1	Window frame - outer	69- ⁷ / ₈ x 2- ¹ / ₄ x ³ / ₄
1	Window frame - outer	69- ⁷ / ₈ x 3- ³ / ₄ x ³ / ₄
Door		
2	Mounting rails	75- ¹ / ₂ x 2 x 1- ¹ / ₈
1	Mounting rail	33- ¹ / ₈ x 2 x 1- ¹ / ₈
1	Alpina doors	76- ¹ / ₂ x 32- ⁵ / ₈ x 4- ³ / ₈
1	Door panel - inside	75- ³ / ₈ x 2- ³ / ₈ x ³ / ₄
1	Door panel - inside	29- ¹ / ₂ x 2- ³ / ₈ x ³ / ₄
1	Door panel - inside	40- ¹ / ₄ x 2- ³ / ₈ x ³ / ₄
1	Door panel - inside	31- ⁵ / ₈ x 2- ³ / ₈ x ³ / ₄
2	Door panel - outside	74- ¹ / ₄ x 2 x ³ / ₄
1	Door panel - outside	33- ¹ / ₂ x 2- ¹ / ₄ x ³ / ₄
1	Door panel - outside	33- ¹ / ₂ x 2 x ³ / ₄
Decor, exterior		
1	Exterior decor D1	100 x 28 x 2
1	Exterior decor D2	21- ¹ / ₈ x 33- ¹ / ₂ x 2
1	Exterior decor D3	95- ³ / ₈ x 28 x 2
1	Exterior decor D4	93- ¹ / ₂ x 30- ³ / ₈ x 2
1	Exterior decor D5	93- ¹ / ₂ x 30- ³ / ₈ x 2
1	Exterior decor D6	93- ¹ / ₂ x 29- ¹ / ₂ x 2
1	Exterior decor D7	95- ¹ / ₂ x 30- ³ / ₈ x 2
1	Exterior decor D8	97- ³ / ₄ x 30- ³ / ₈ x 2
1	Exterior decor D9	100 x 29- ¹ / ₂ x 2
1	Exterior decor D10	100- ¹ / ₄ x 30- ³ / ₈ x 2
1	Exterior decor D11	6- ⁷ / ₈ x 30- ³ / ₈ x 2
1	Exterior decor D11-b	23- ³ / ₈ x 30- ³ / ₈ x 2
1	Exterior decor D12	100- ¹ / ₄ x 29- ¹ / ₂ x 2
1	Mounting rail - under the door	33- ¹ / ₂ x 1- ⁵ / ₈ x 1- ¹ / ₈
Interior fittings		
2	Bench support slats	22- ⁷ / ₈ x 1- ⁵ / ₈ x 1- ⁵ / ₈
1	Bench support slats	20- ⁷ / ₈ x 1- ⁵ / ₈ x 1- ⁵ / ₈
2	Bench support slats	47- ¹ / ₄ x 1- ⁵ / ₈ x 1- ⁵ / ₈
2	Mounting slats for bench screen	10- ¹ / ₄ x 1- ⁵ / ₈ x 1- ⁵ / ₈
2	Benches	70- ¹ / ₂ x 24- ³ / ₈ x 3- ¹ / ₂
1	Bench	52- ¹ / ₂ x 24- ³ / ₈ x 3- ¹ / ₂
1	Backrest	74- ³ / ₄ x 10- ¹ / ₄ x 1- ³ / ₄
1	Backrest	71- ¹ / ₄ x 10- ¹ / ₄ x 1- ³ / ₄
1	Bench screen	70- ¹ / ₂ x 13- ³ / ₄ x 1- ⁵ / ₈
1	Bench foot	48 x 36- ¹ / ₄ x 2- ³ / ₈
8	Corner cover strips	78- ³ / ₄ x 1 x ³ / ₄



PARTS LIST CONTINUED

No. of items	Name	Dimensions inches	No. of items	Name	Dimensions inches
Accessories					
1	Ventilation slide - Inner	20-1/2 x 5-1/2 x 5/8	1	Door handle set Alpina - Outer door	25-3/8
1	Ventilation slide - Inner	11-1/4 x 4-3/4 x 5/8	1	19' 8" silicon cables: 5 x 10 Gauge	
2	Ventilation grille outer	11-1/4 x 4-3/4 x 5/8	1	13' 1" silicon cables: 3 x 15 Gauge	
4	Sauna ventilation cover, stainless steel	Ø 2-1/2	3	Spacers for door and window Installation	3-7/8 x 1-5/8 x 1/4
1	Floor grid	27-1/2 x 20-7/8 x 1-5/8	1	Roofing felt	107-5/8 ft ²
2	Headrests	16-7/8 x 10-1/4 x 2-3/4	1	Installation material set	
1	Lamp protective grille 920S		1	Assembly Instructions	
1	Lamp without bulb				

FLOOR/FOUNDATION PLAN

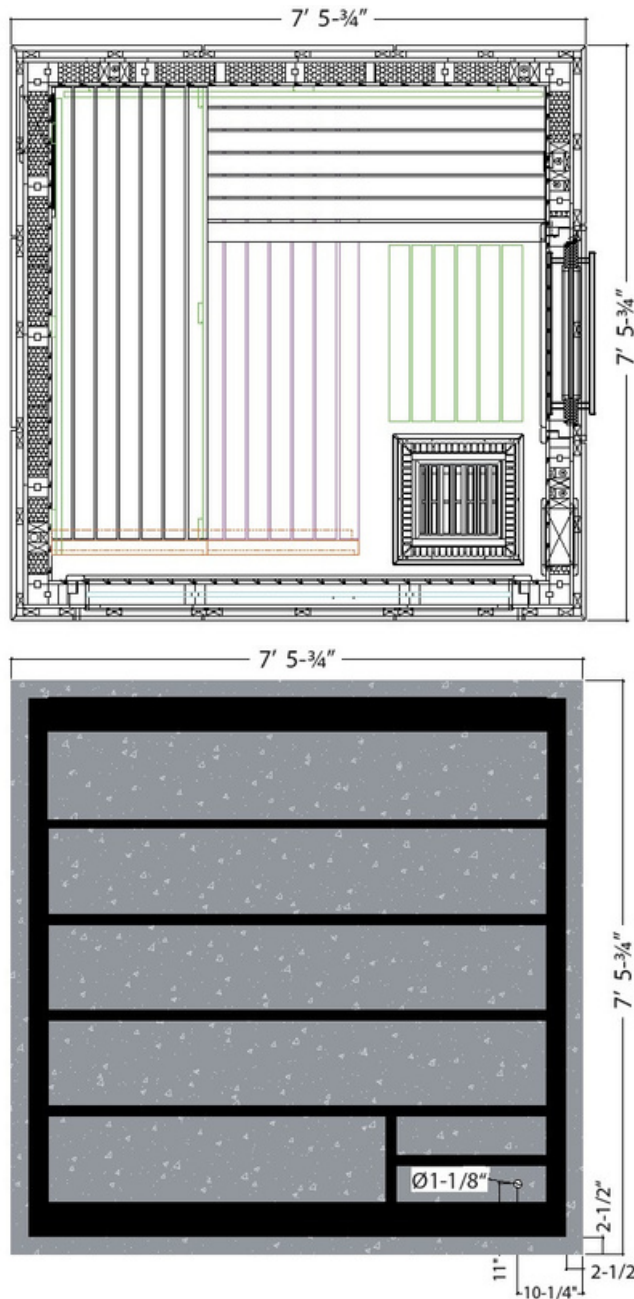

BASE ASSEMBLY



Ensure sauna foundation is sturdy, level, and can carry the weight of the sauna. If the foundation is not,

the base wood and the sauna foundation. We also recommend anchoring the sauna to the sauna foundation to prevent damage in the event of strong winds.

Place the outer floor frames centered on your foundation per the floor plan. Attach the floor frames together by pre-drilling and using eight 5 X 70 screws (1). Place the inner base floor frames inside the outer floor frames per the floor plan. Attach the inner base floor frames together by pre-drilling and using eighteen 5 X 90 screws (2). Attach the inner base frames that run next to the outer base frames using three screws in each.

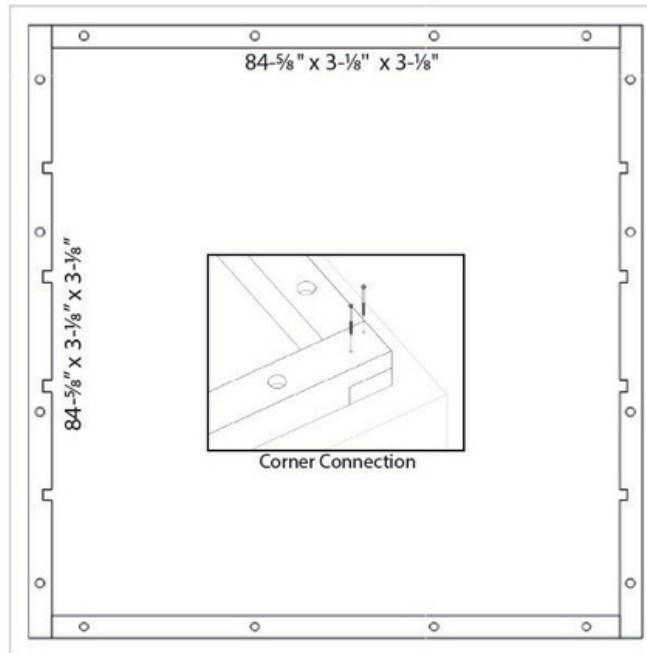

Image 1

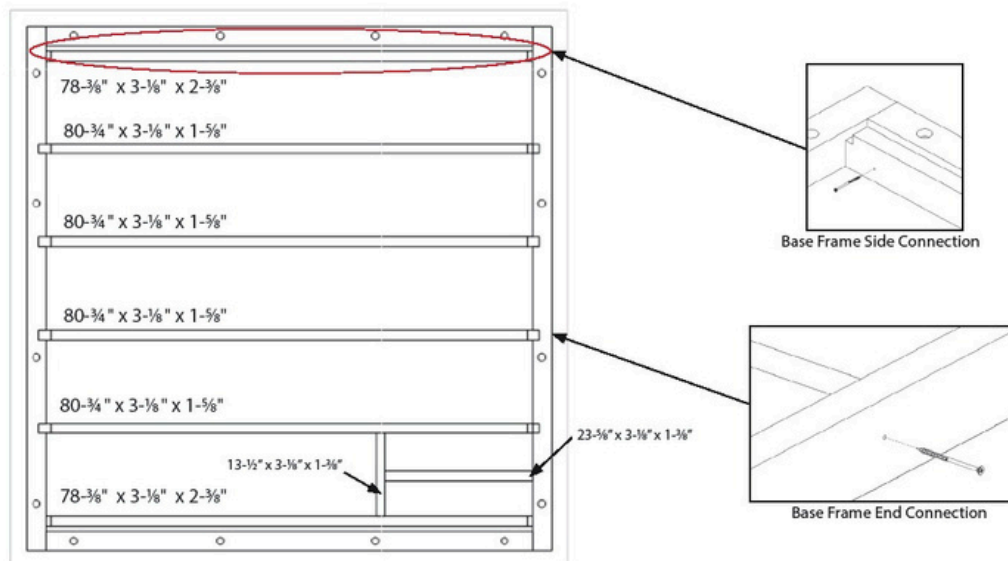

Image 2

**WALL ASSEMBLY
NOTICE**

- **ALL SCREWS MUST BE PRE-DRILLED BEFORE INSTALLING TO PREVENT BREAKAGE.**
- **Never hit the groove of the wall panels directly with a hammer, use a wooden strip/block in between.**
- **Check that the corners are a right angle when connecting before full fastening.**

Start by fastening wall element 1 (W1) and wall element 2 (W2) to a corner post in the back right base corner by using four 6 X 130 screws (3-4). Then attach wall W3 to W2 by using one 5 X 70 screw; as well as W4 and W5 (5). Place another corner post in the back left and attach to W5 using 6 X 130 screws (6). Then place W6-W9 by fastening using one 5 X 70 screw (7).

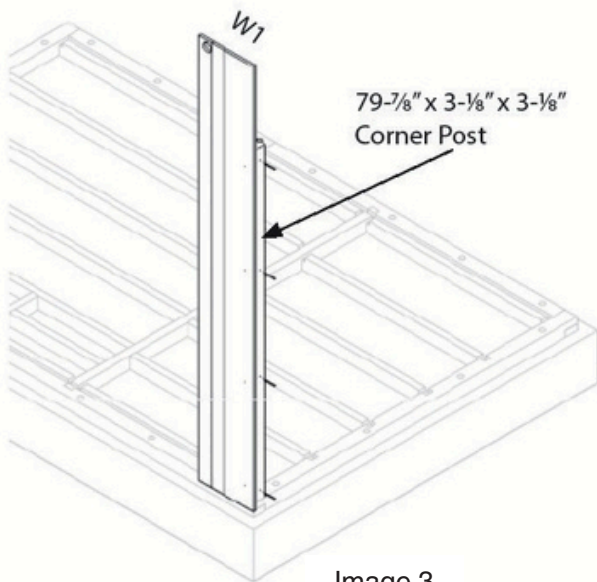

Image 3

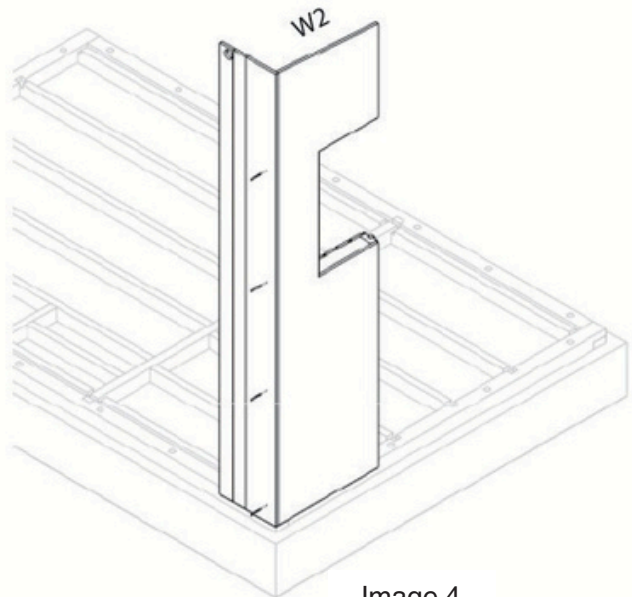

Image 4

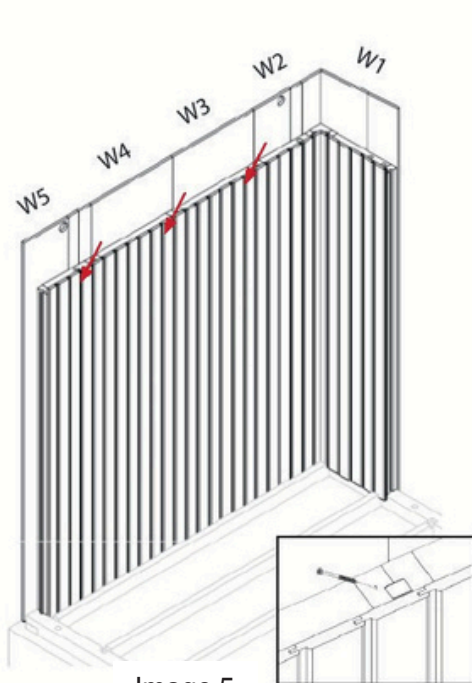

Image 5



Image 6

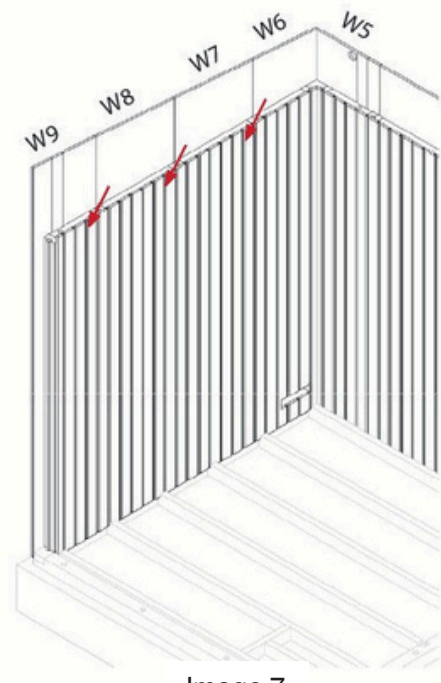

Image 7

Place the next corner post and fasten to W9 using four 6 X 130 screws. Fasten wall W10 to the corner post using four 6 X 130 screws (8). Then place walls W11 and W12 and fasten using two 5 X 70 screws (one in each connection) at the wall joint (9). Connect W10 and W12 using W11 Mounting Rail and six 5 X 70 screws, and install wall W11-b (10). Connect W11-b to W10 and W12 using 5 X 70 screws. Place the last corner post and fasten to W12 using four 6 X 130 screws. To complete the outer wall assembly remove the screws from the base frame and slightly separate (11a) , place W13 and fasten to the corner post using four 6 X 130 screws. Place W14 (door frame element) between W13 and W1 and fasten using two 5 X 70 screws (one in each connection) at the top of the wall joint (11). Now using rubber mallet, get the base frame back square and fasten together by pre-drilling and using two 6 X 130 screws (11b).

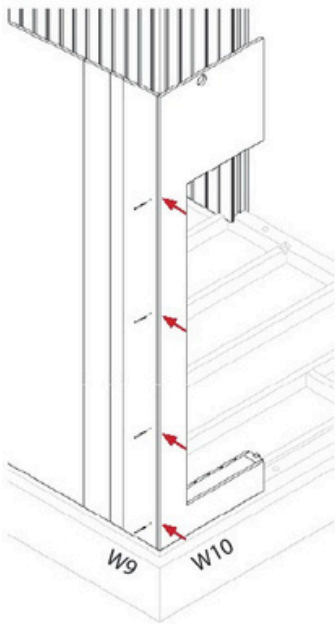

Image 8

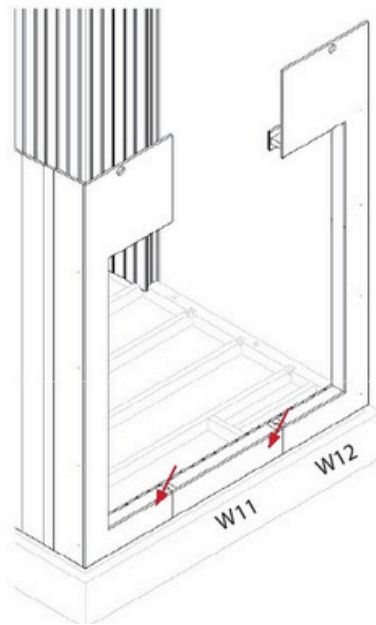

Image 9

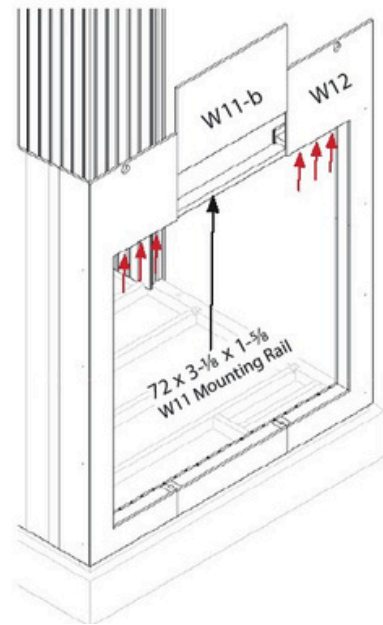

Image 10

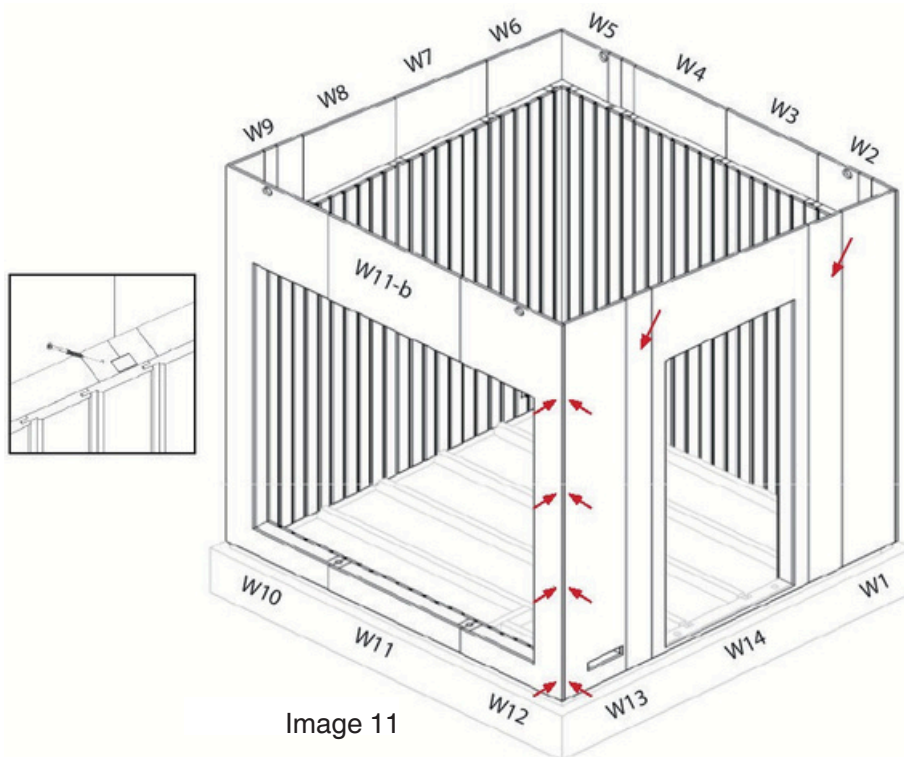

Image 11

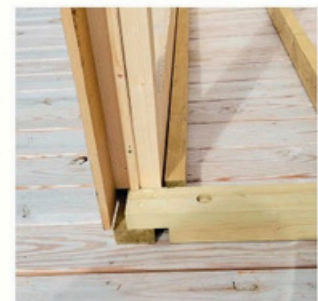

Image 11a

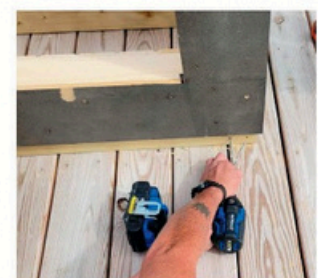

Image 11b

FLOOR INSTALLATION

Starting on the right side in front of the door, lay a floor board (groove side against the wall) and fasten using 3.2 X 40 screws on each side. **Note:** W13 is not shown so you can see the screw connections. On the wall edge go down through the board into the base frame, and on the opposite side fasten through the tongue into the base frame (12). Ensure the screws are countersunk so the next floor board does not have interference issues. Continue by placing floor boards groove over the tongue of the previous board. Fasten using six 3.2 X 40 screws to connect the floor board to each base frame (13). Once you get to the last board, you may need to cut the boards width to fit the gap. Fasten down through the top of the floor board at the edge into the base frames using six 3.2 X 40 screws (14).

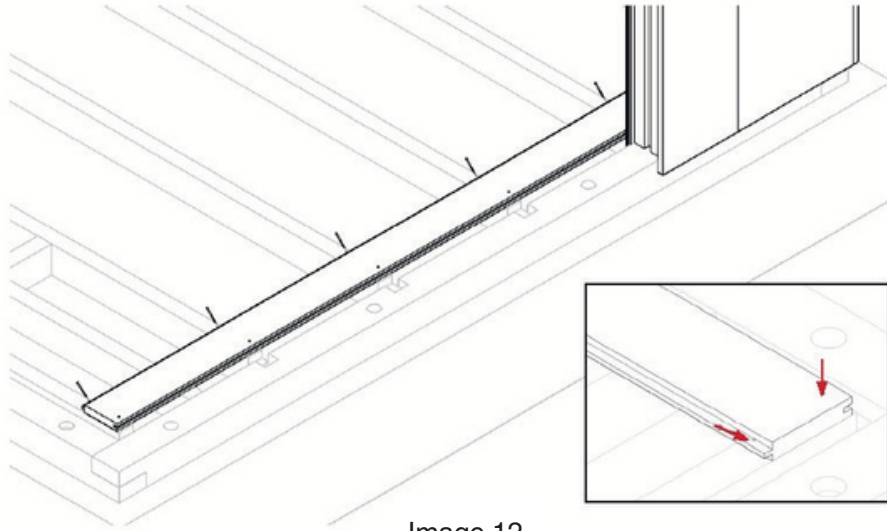

Image 12

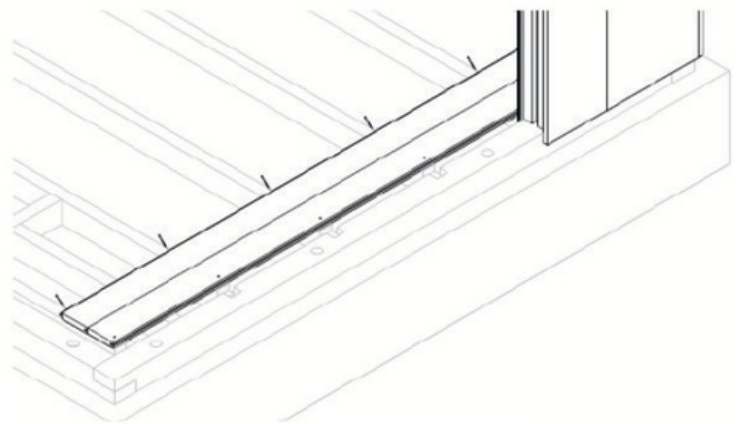

Image 13

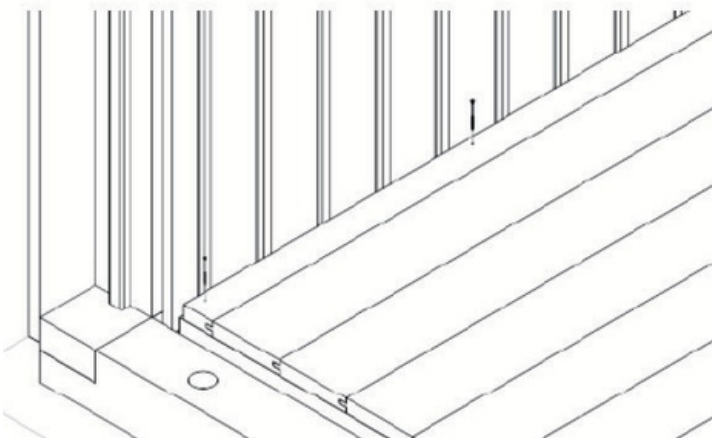

Image 14

ELECTRICAL CABLE INSTALLATION

You light will go in the corner of W1 and W2 and use the cable channel in W2 for the wiring. Drill a hole through the wall to access the cable channel to route the wire, then fasten the light to the wall (15-16). Ensure the light isn't against the ceiling, so there is room to install the corner cover strips. If using the lamp protection grille, it must be in the corner so it can span the corners and fasten using four 3.5 X 40 screws (17). It's easiest to hold off on installing the grille until after the corner covers are installed..

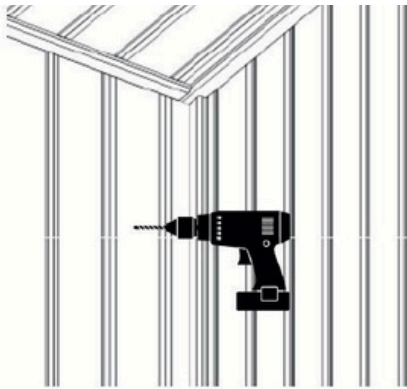

Image 15

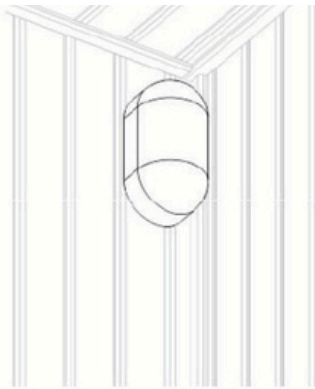

Image 16



Image 17



DANGER

- Turn off power to heater at breaker before beginning installation or performing maintenance on the heater.

For the heater, use the cable channels in wall W13 to run the wires for the heater and temperature sensor (if required). You can run them up into the ceiling and then down another cable channel, and exit to the outside closest to the location of your incoming power. The cable channels can also be used to run the wires if your heater uses a digital controller. This step could be done once the inside ceiling is in place, but it is easiest to be able to locate and drill into the cable channels. When installing the ceiling in the next steps, make sure the components are placed correctly with the notches and cutouts so they don't interfere with your wire paths.

There are exterior wall components that fasten to the outside of the sauna. We would recommend not connecting the heater to incoming power until during or after that step to see the optimal location and method of connection. See the Heater section later in this manual for more information about the heater installation.

ROOF INSTALLATION

Gather the four roof support strips and fasten on top of the walls using four 5 X 70 screws in each strip(18). Ensure the notches for the cables are oriented correctly.

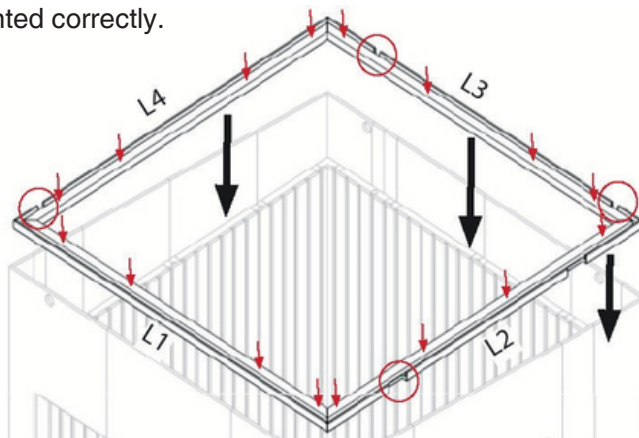

Image 18

Lay the three roof elements onto the roof support strips, and fasten using fourteen 6 X 120 screws (19). Ensure the inspection opening and cable notches are oriented correctly.

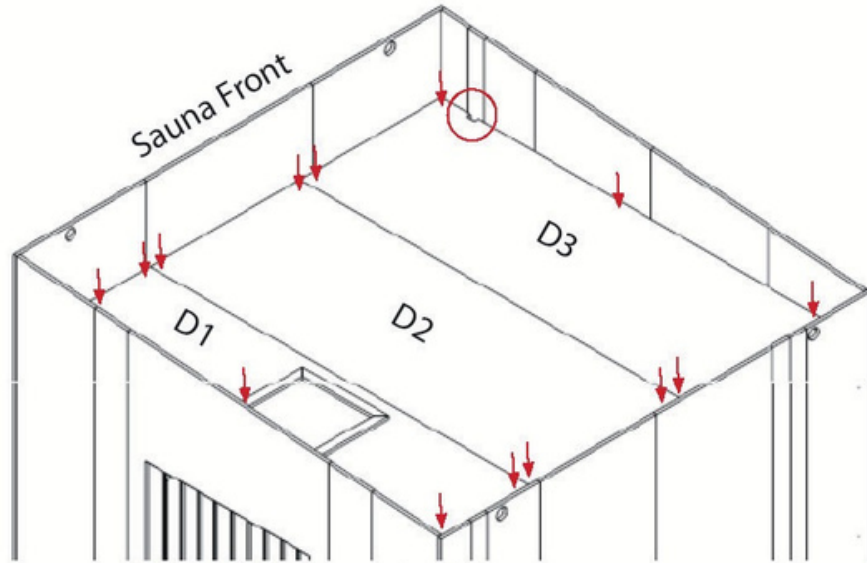

Image 19

In the front of the roof, install the first layer of 4-5/8" roof rafter supports using four 6 X 200 screws (20). Repeat for the second layer of 4-5/8" roof rafter supports using four 6 X 200 screws (21). The final height of the front roof rafter supports should be 9-3/8". In the back, use the single 3-1/8" tall roof rafter support and fasten using four 6 X 150 screws (22). Ensure the cutouts are oriented properly.

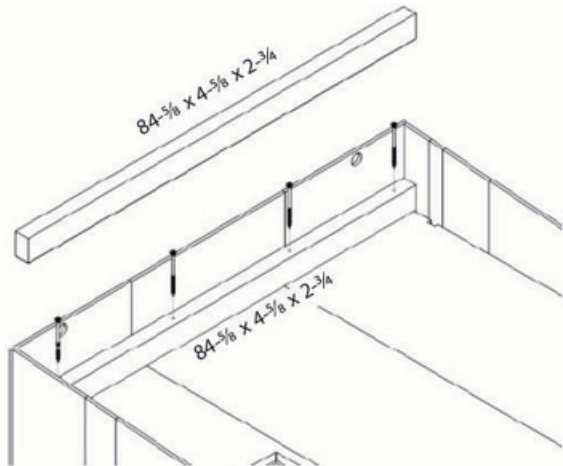

Image 20

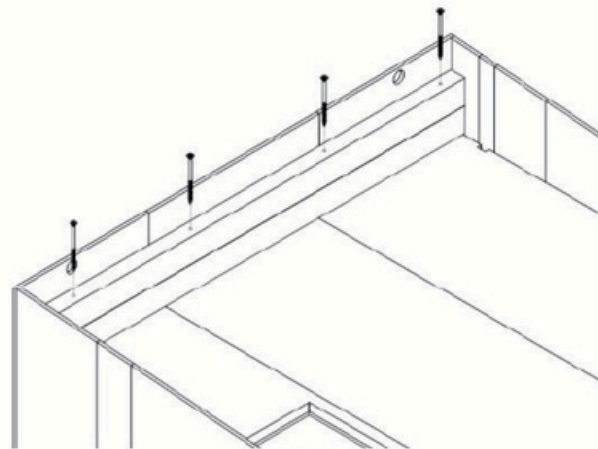

Image 21

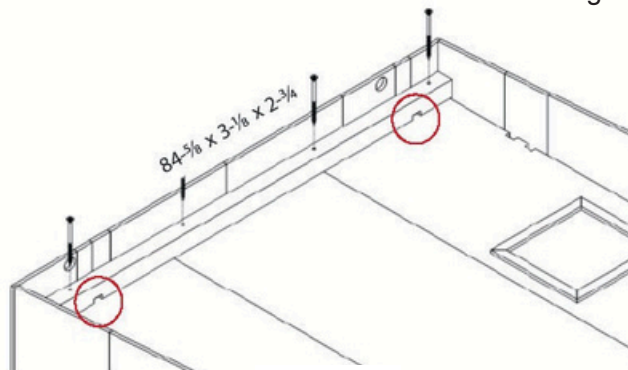

Image 22

PARTITION INSTALLATION

Locate the front mounting rail and fasten it to wall W17 using four 5 X 80 screws; ensure the mounting rail is aligned with W19 (22). Then fasten the front stand with glass groove to the front mounting rail using four 3.5 X 50 screws (23). Locate the rear stand with glass groove and slide it down over the multiclips to connect it to W19 (24).

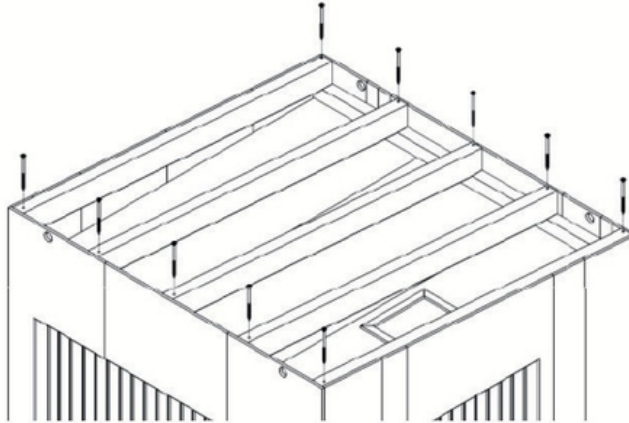

Image 23

Place the 2 roof panels (89-3/4 x 45 x 3/4) on top of the rafters and fasten using fifty 4 X 50 screws. Fasten the screws into the rafters, 5 per rafter per panel (24-25). Place the sheets of roofing felt over the roof panels using a 22-1/2" overlap, and attach using eighty roofing nails (26). We recommend 8 rows of nails, two in each row for the 3 lower sheets; then 4 in the last top sheet. Insert the 4 stainless steel ventilation covers into the outside of walls W2, W5, W10, and W12 (27).

NOTICE

- We recommend purchasing shingles, metal roofing, or another suitable roof covering from your local hardware

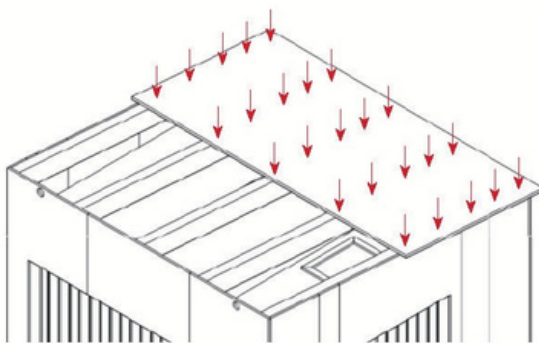

Image 24

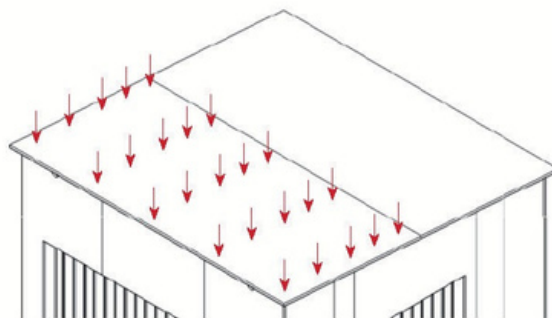

Image 25

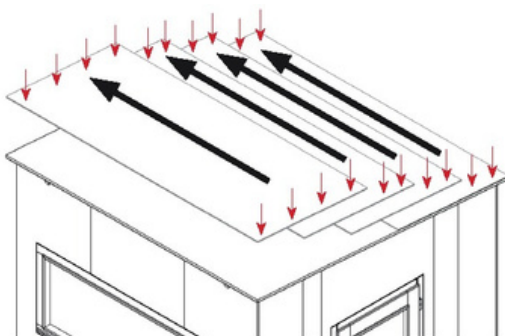

Image 26

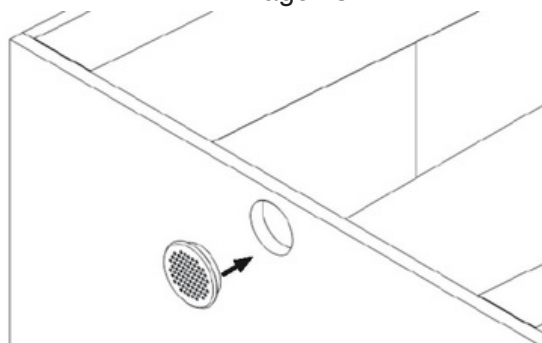

Image 27

WINDOW & DOOR INSTALLATION

Place the window mounting rails into the window opening, offset in the opening to the inside of the sauna, and fasten using fourteen 4 X 70 screws in each window (28-29). Install the window from outside the sauna. Pre-drill through the window mounting rails and fasten through the mounting rails into the window frame using fourteen 5 X 80 screws for each window (30-31).

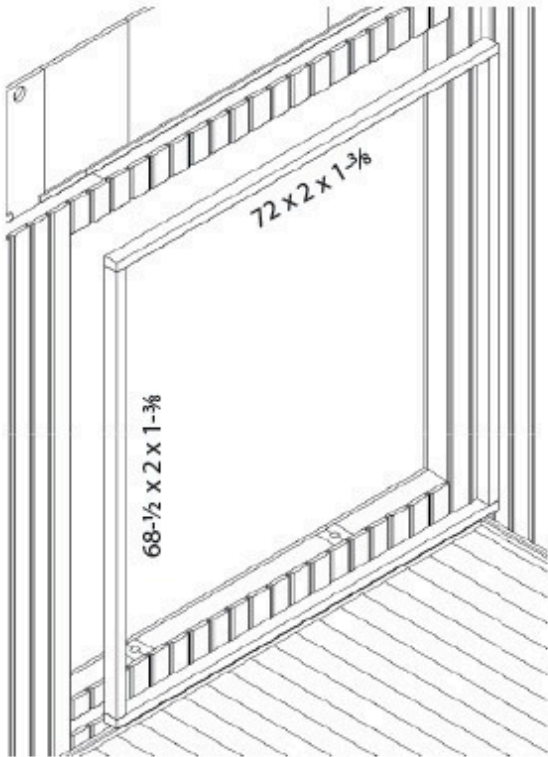

Image 28

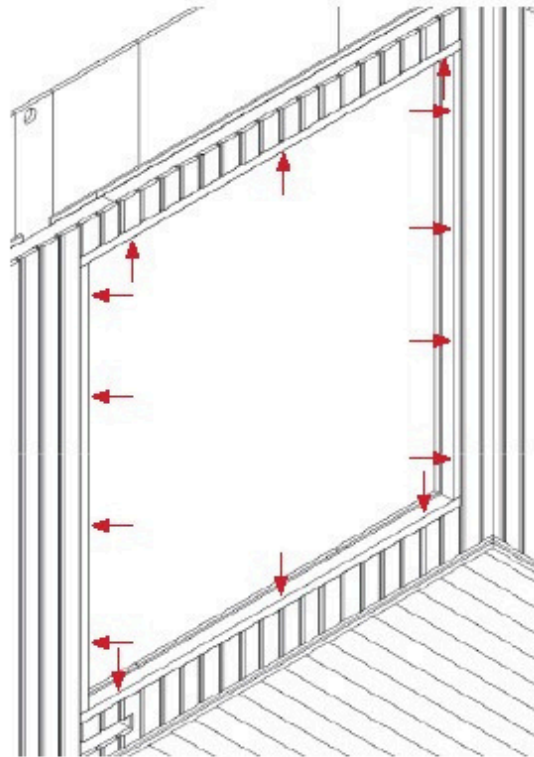

Image 29

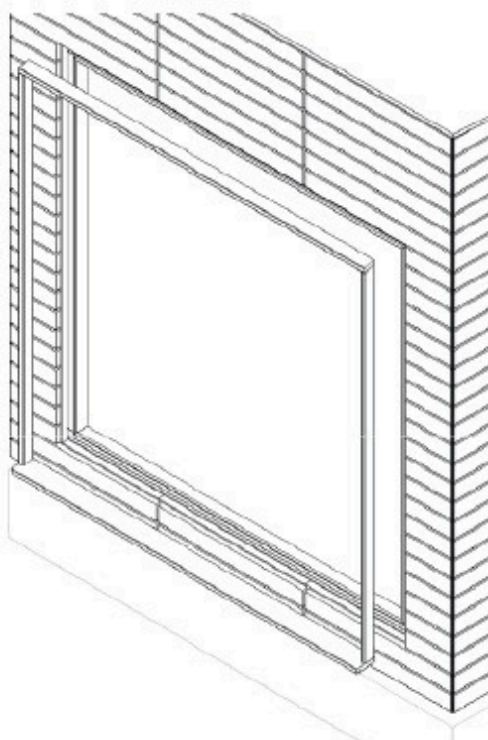
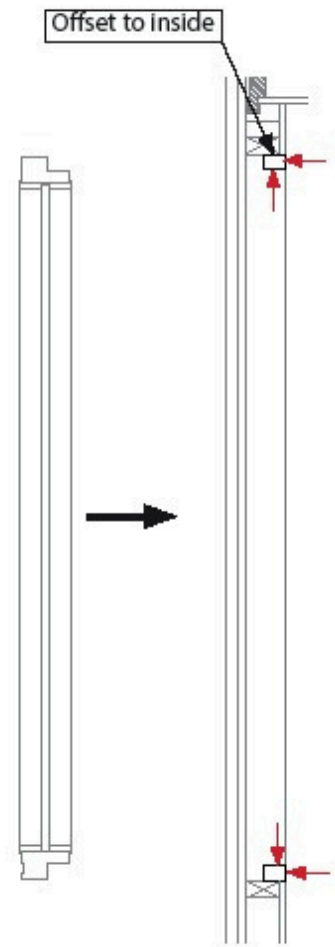

Image 30

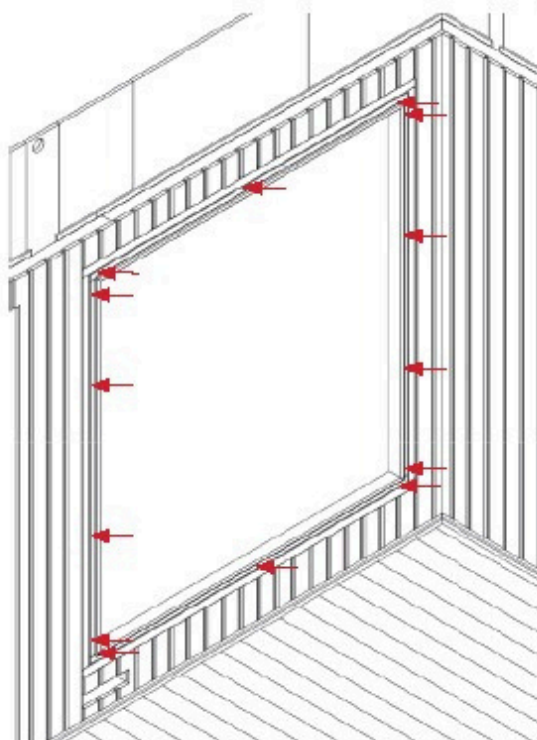

Image 31

Cover the window opening with the inner window frame, and fasten using sixteen 3.2 X 40 screws in the window (32).

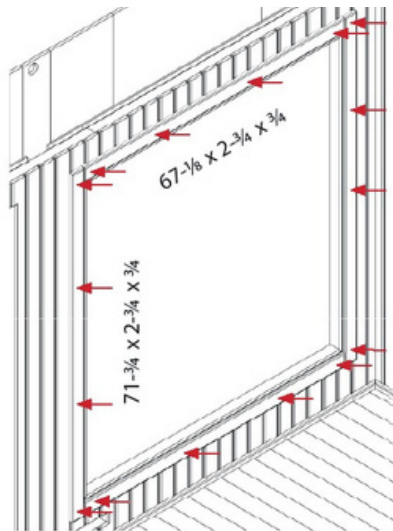

Image 32

Install the door handles onto the door (33). Place the door mounting rails into the door opening, offset in the opening to the inside of the sauna similar to the window, and fasten using ten 4 X 70 screws (34-35). Set the door in the opening from the outside, pre-drill and fasten through the mounting rail using ten 5 X 80 screws (36-37). Cover the door opening with the inside door cover strips and fasten using thirteen 3.2 X 40 screws (38).

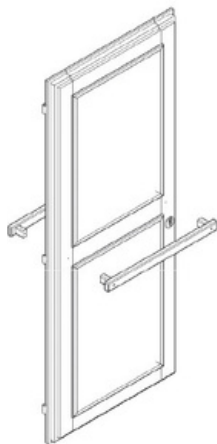

Image 33



Image 34

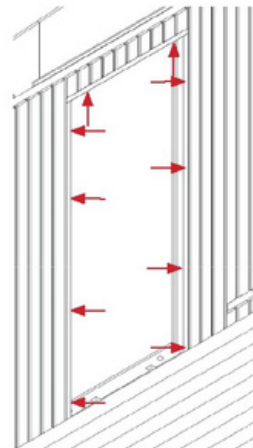

Image 35



Image 36

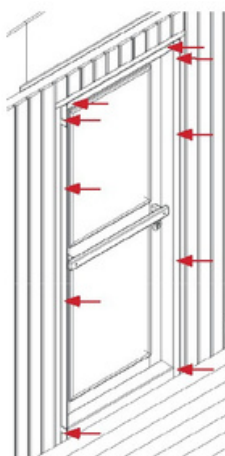

Image 37

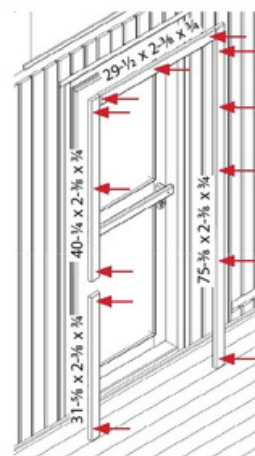

Image 38

BENCHES, BACKRESTS & OTHER INTERIOR COMPONENT INSTALLATIONS

Fasten the skirting boards around the base of the floor using sixteen 3.2 X 40 screws (39). Install the ventilation slides over both exhaust openings using four 3.5 X 40 screws for each (40).

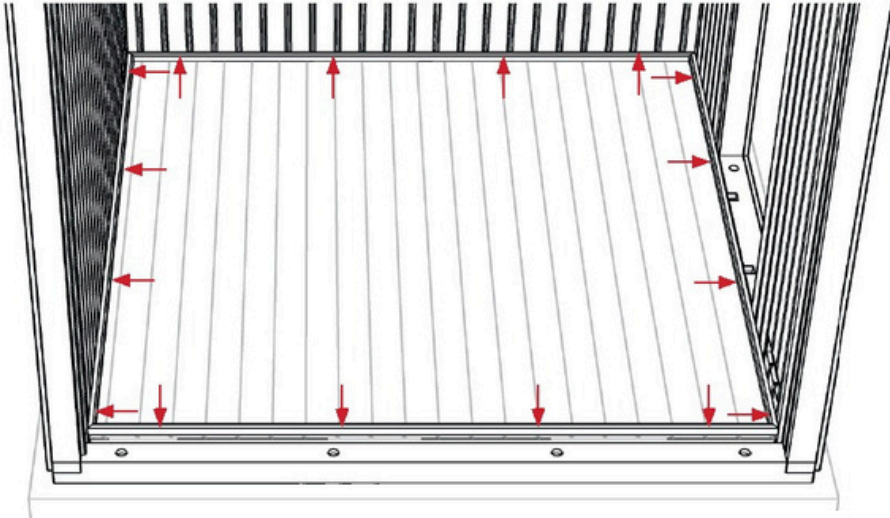

Image 39

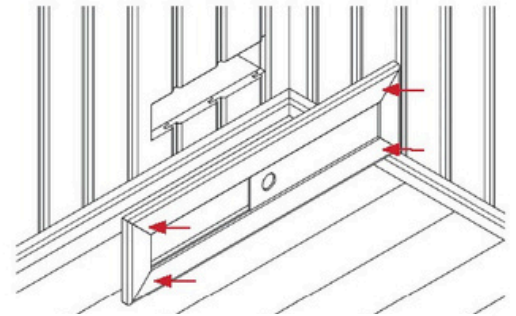

Image 40

NOTICE

- ALL SCREWS MUST BE PRE-DRILLED BEFORE INSTALLING TO PREVENT BREAKAGE.

Position the bench foot wall in front of W10/W11, and fasten it to W9 using three 5 X 120 screws. It should be roughly 70-7/8" from the back wall to the bench foot wall; the feet also adjust if required. Mount the two 22-7/8 x 1-5/8 x 1-5/8 bench braces by pre-drilling and using three 5 X 70 screws in each to connect to the wall. Also, the two 47-1/4 x 1-5/8 x 1-5/8 bench braces by pre-drilling and using three 5 X 70 screws to connect to the wall. Fasten the two 10-1/4 x 1-5/8 x 1-5/8 bench screen mounting slats using two 4 X 60 screws in each (41).

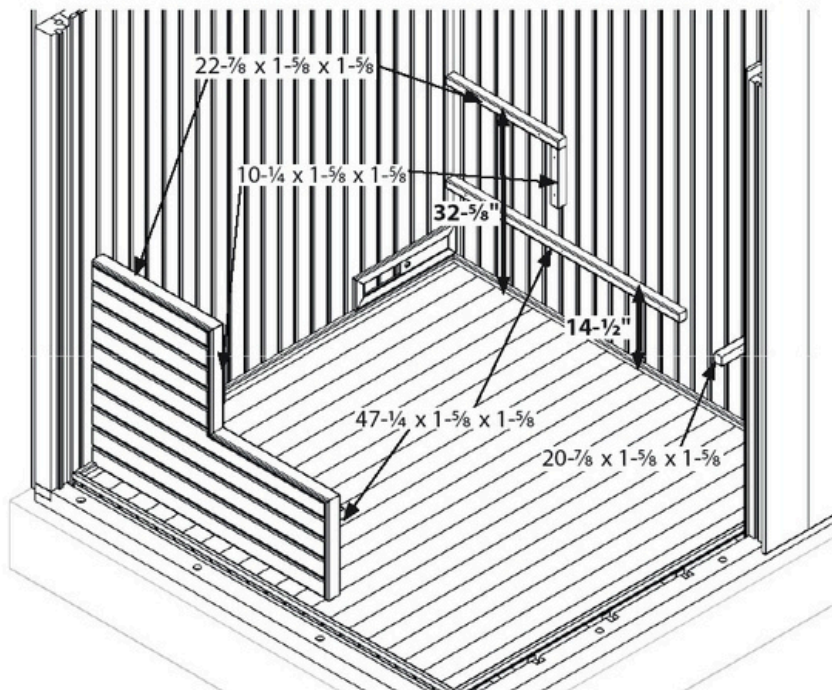
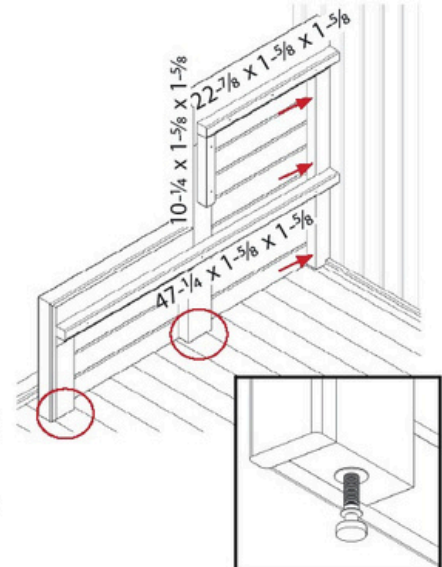

Image 41



Place a 70-1/2" bench on the left wall of the sauna, then place the 52-1/2" upper bench on the back wall and screw it into the face of the left bench using three 5 X 70 screws (60). Place the bench screen against the bench screen mounting slats and screw from the back using four 3.5 X 50 screws. Then place the remaining 70-1/2" bench on the lower supports. Lastly, place the 44-7/8" bench on the supports in the entrance area (61). For the backrest, you can set at a height of your choosing, but we recommend approximately 8" above the top bench. Fasten to the wall using three 3.5 X 40 screws in each back rest (62).

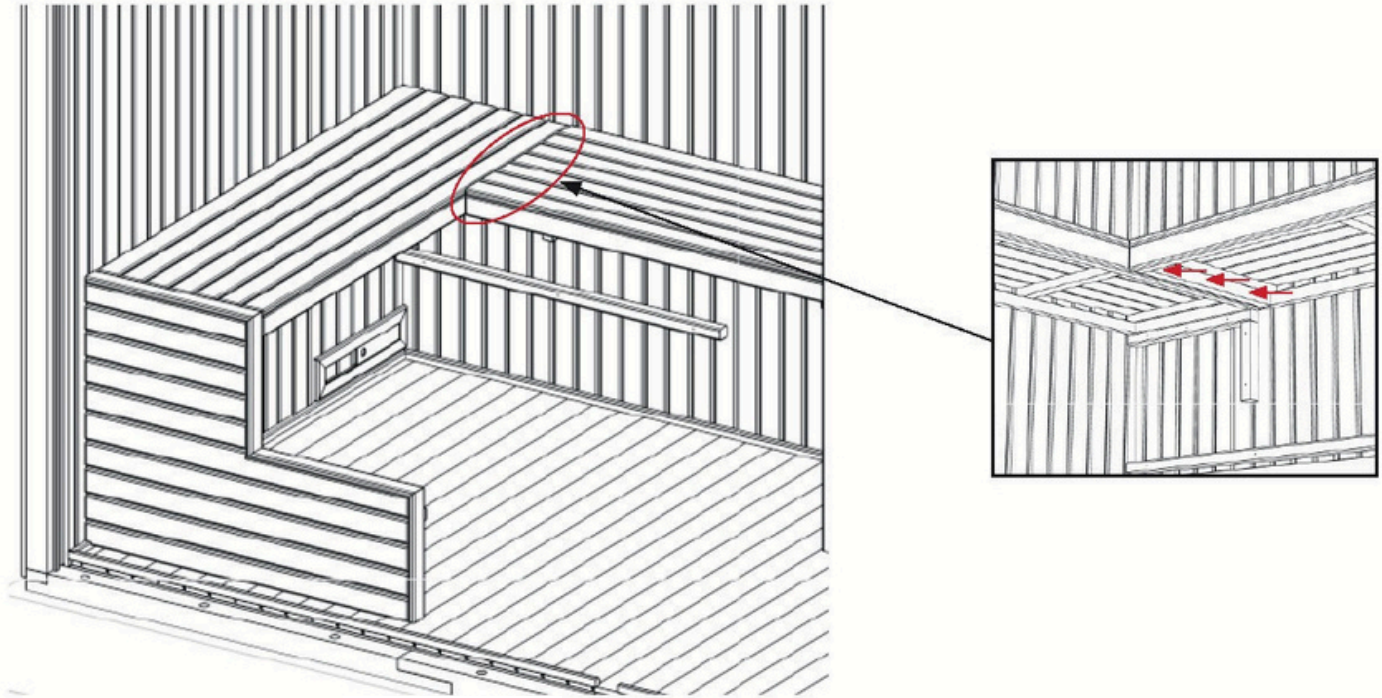

Image 42

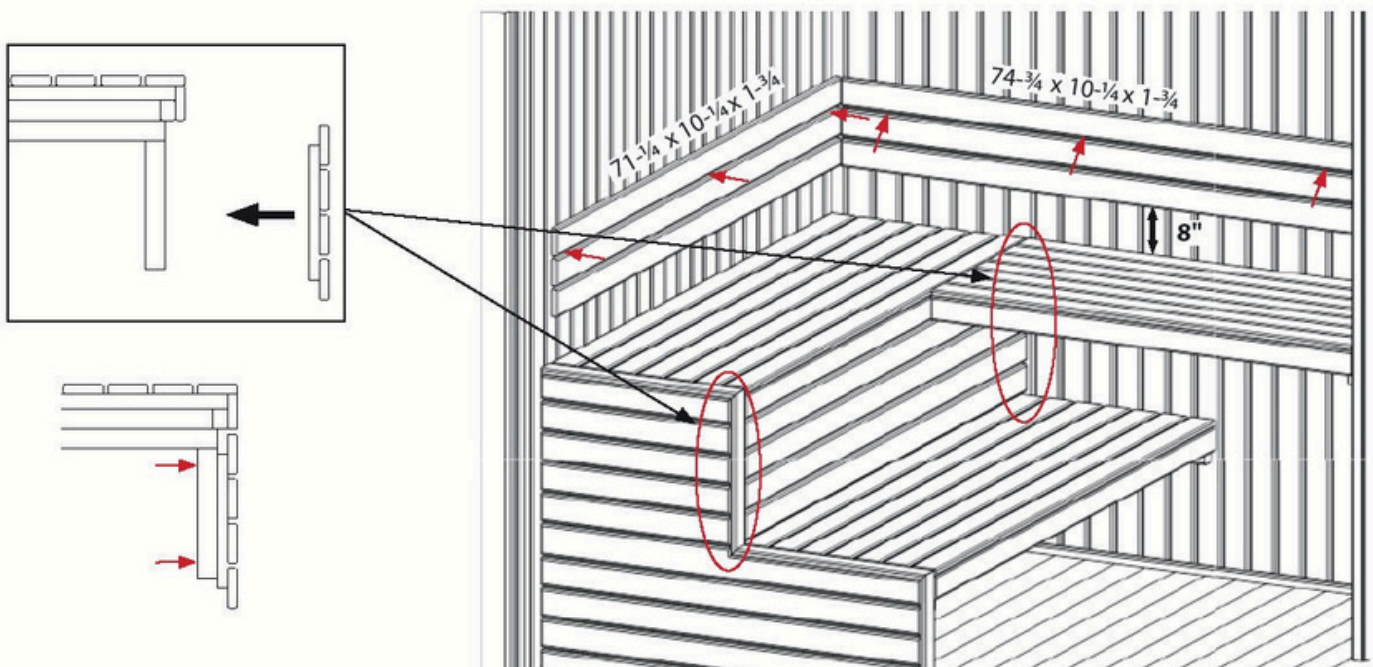

Image 43

Use the corner cover strips to conceal the vertical wall joints and ceiling joints; measure and cut to required length. Fasten them to the wall using three to five 3.2 X 40 screws per strip depending on length, but no more than forty (44).

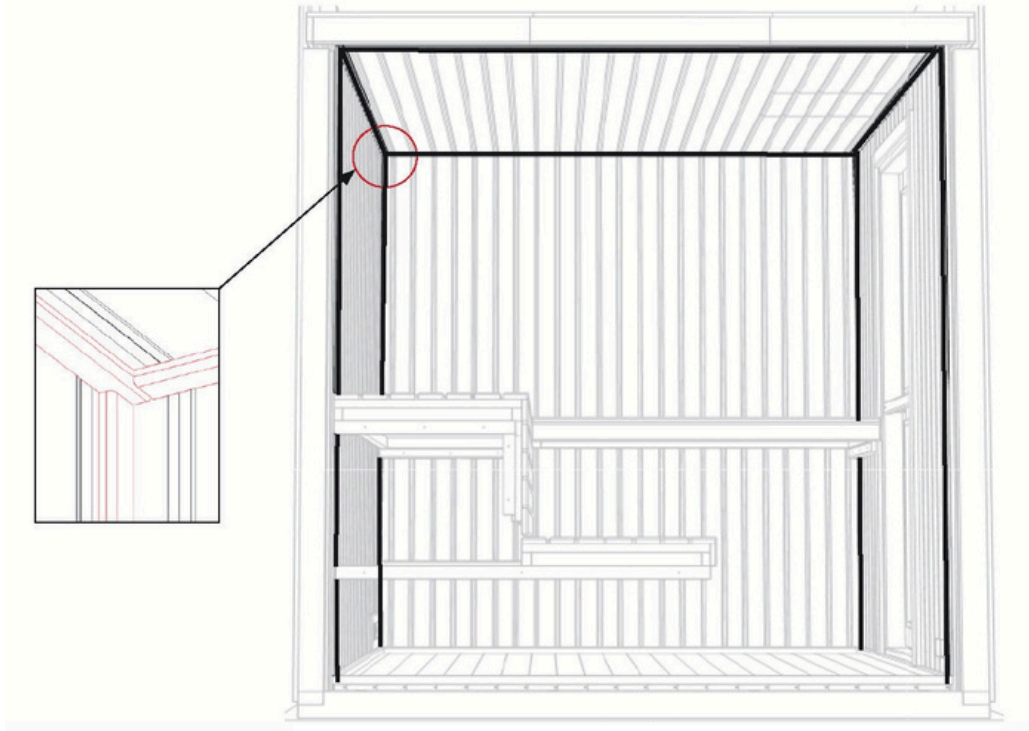

Image 44

EXTERIOR DECOR INSTALLATION

Install the exterior decor starting with element D1. Place the panels 2-1/2" off the foundation, and fasten using five rows of three 4.2 X 70 screws (45). **Note:** Panorama model is shown in 45 & 48, but View model installs the same way. Repeat for D2 and D3 (46).

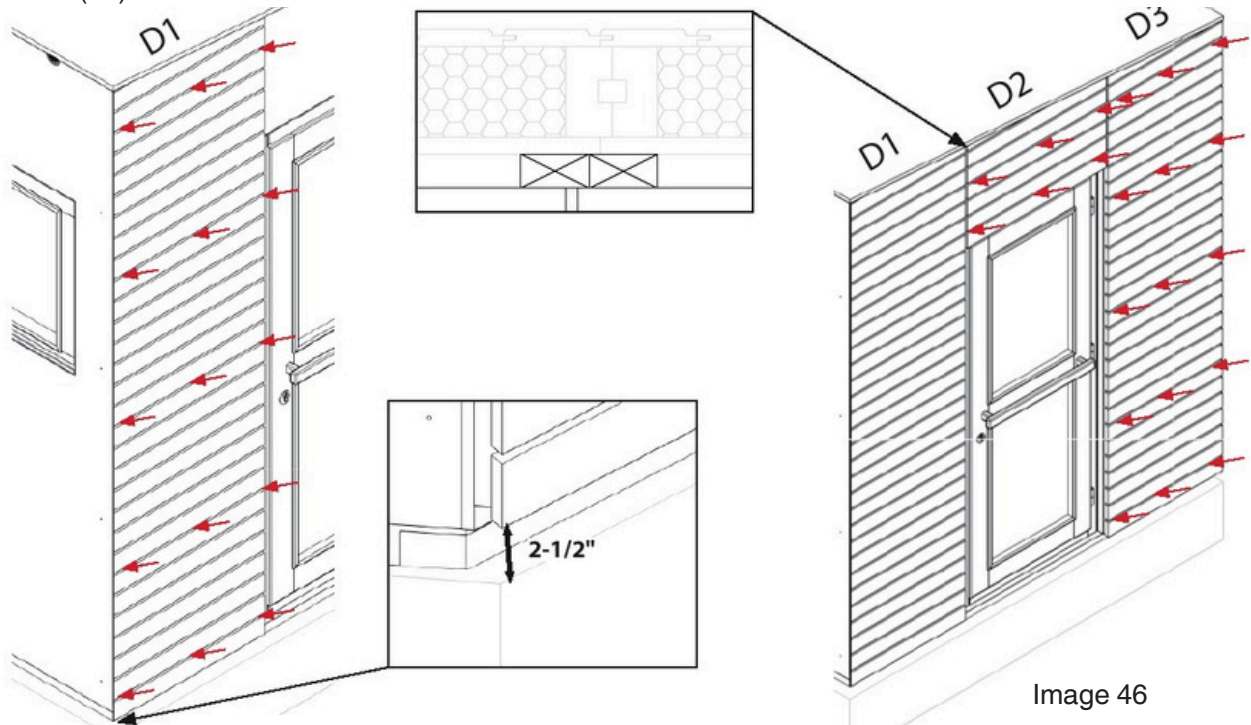

Image 45

Image 46

Fasten the outer ventilation grill over the outside openings in the sauna using four 3.5 X 40 screws in each. Work around the back and left sides placing the exterior decor panels finishing with D6. (47). The left side (D7-9) will be the same as D4-D6. Lastly install the front decor (48).

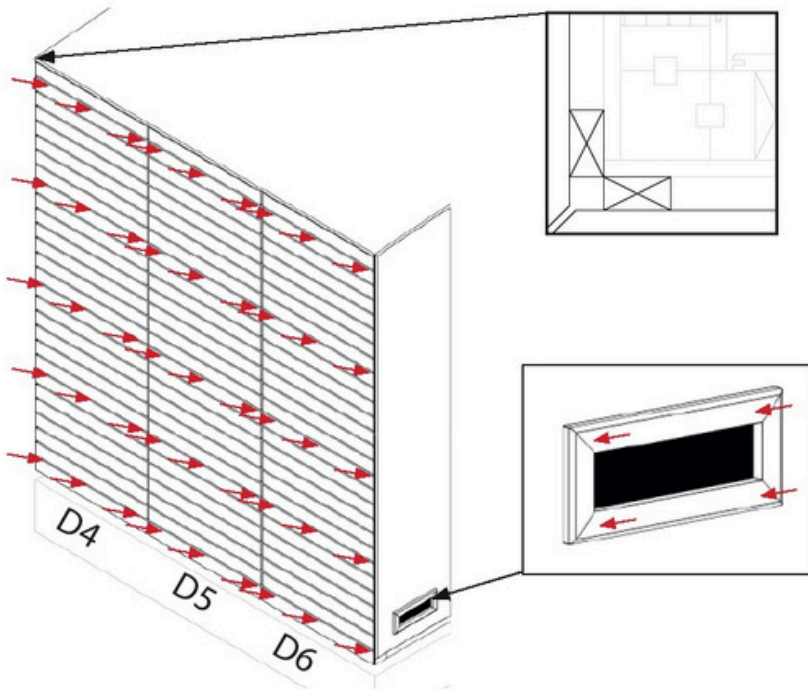

Image 47

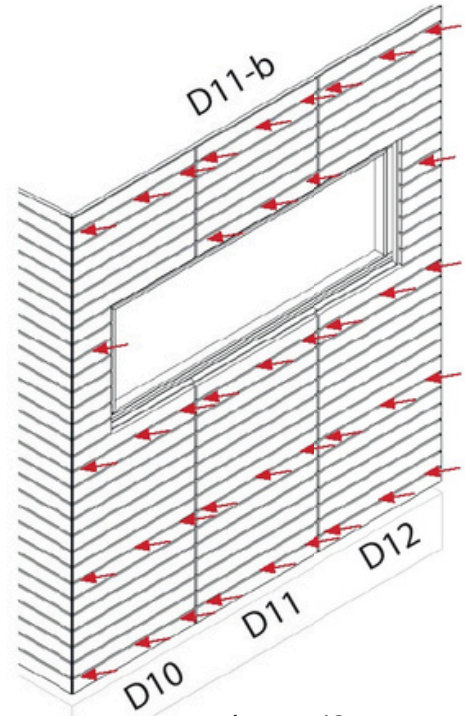

Image 48

Continue working around the sauna back and left side placing the exterior decor panels finishing with D14. In narrow sections, rows may only fit two 4.2 X 70 screws (67).

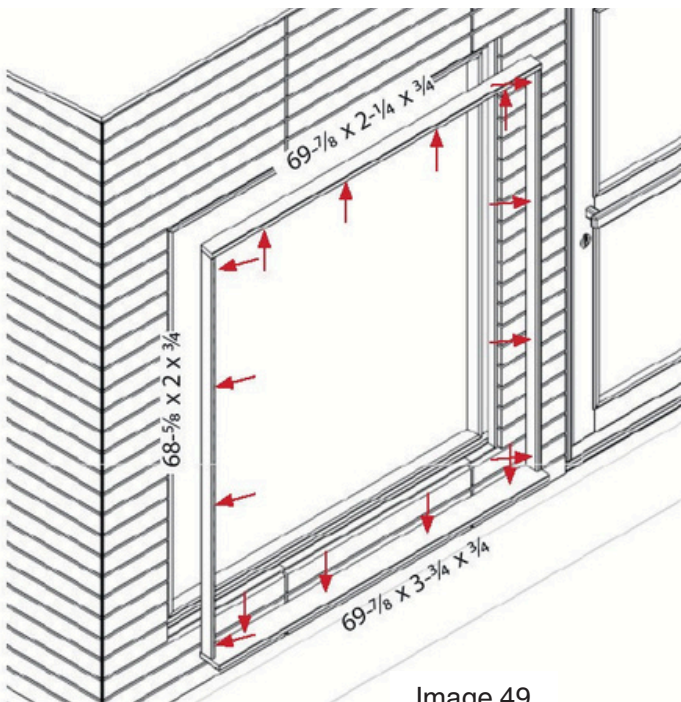

Image 49

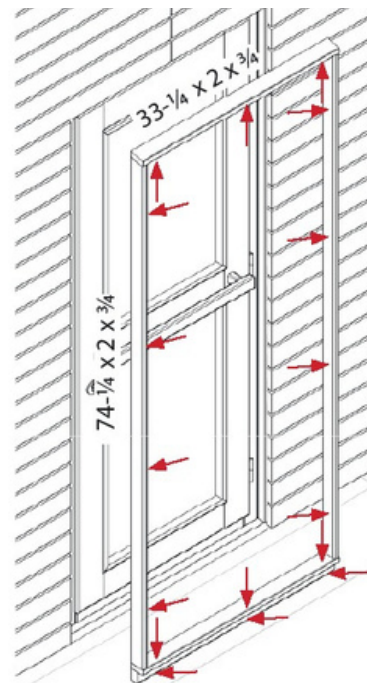

Image 50

Your sauna also comes with 2 head rests and 1 floor grid. The floor grid can be placed at your discretion (51).

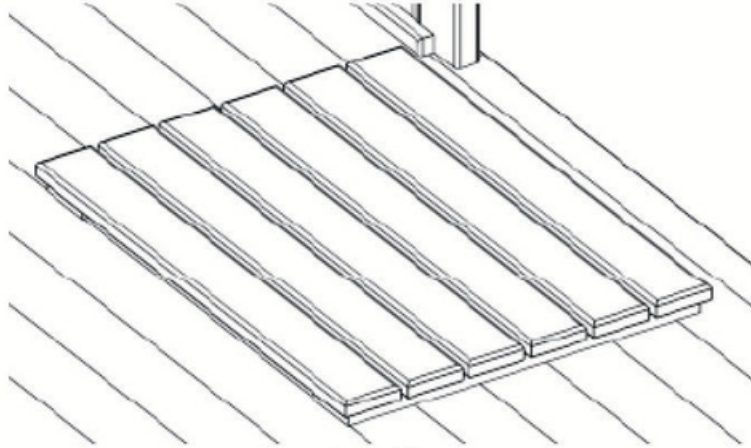

Image 51

HEATER - Please see heater manual.

 **DANGER**

- Turn off power to heater at breaker before beginning installation or performing maintenance on the heater
Failure to turn off the power will lead to electrocution and even death.

 **CAUTION**

- Improper installation of heater or heater mounting bracket could cause the heater to fall leading to burns and other injuries.
- Before placing or adjusting stones, ensure heater is back to room temperature. Failure to do so may cause burns.



FINAL THINGS

Once assembly is complete, sweep and vacuum the inside of the sauna. Wipe down the entire interior with a damp cloth to remove any remaining dirt, dust and debris.

Note: If the sauna has absorbed moisture in storage, the staves may shrink as the high heat evaporates that moisture. This may require you to tighten the band even further. If your sauna is left in the open rain, this will cause the staves to expand again resulting in an event tighter seal.

The wood of the outdoor sauna is untreated. To increase the durability of the wood, we recommend treating the outside only with an exterior grade stain or sealant of your choice. This will help to protect the wood from excessive moisture.

TRADITIONAL SAUNA USE

Congratulations! You are ready to enjoy your barrel sauna! You may use your sauna in a wet or dry fashion. Dry, meaning you do not sprinkle any water onto the stones; wet, meaning you increase the humidity of the room by sprinkling water on the stones. Please note, not much water is needed to achieve a wet sauna experience. The sauna as we know it originates in Finland. The typical sauna experience follows the steps below, but you may enjoy your sauna in any way you like!

- Set your heaters so your sauna achieves the desired temperature. This is typically 160-185+ degrees F.
Novice sauna users should begin at the lower end of that range and increase their high temperature over time.
- Take a quick shower or a quick dip in a hot tub or pool.
- Step into the sauna and enjoy for 5-15 minutes, bringing a towel to sit or lay on. Leave the sauna once you are perspiring freely.
- Take a plunge in a pool, shower, snow bank, lake-anything that will cool you down! After that, relax and cool down for 10-20 minutes.
- Step into the sauna again. During this visit, you may wish to sprinkle small amounts of water onto the stones to create bursts of steam. If water spills through the heater to the floor, you are using too much water, though this will not hurt the heater or the sauna.
- Continue repeating this process. After your final visit to your sauna, relax for at least 20 minutes. Shower with warm water initially, finishing with cool water to close your skin pores.
- Prepare to feel refreshed for the day or to have an amazing night's sleep!

Whatever your sauna routine, it is imperative that you **STAY HYDRATED!**

This product manufactured by

ALMOST HEAVEN
SAUNAS



CARE & MAINTENANCE

TREATING LUMBER

The lumber we use is naturally resistant to the elements. Left untreated, the exterior of the sauna will weather naturally, and that's fine. At any point in the future you can pressure wash (low pressure only) your sauna to bring back most of the original color.

If you wish to retain the natural color of the lumber, your local paint store can recommend a suitable exterior stain. Be sure that it has a UV inhibitor so that it will best resist the effects of sunlight. Follow the manufacturer's instructions for application. NEVER TREAT THE INTERIOR OF THE SAUNA UNLESS APPROVED FOR USE IN A SAUNA, AND NEVER USE VARNISH OR PAINT ON THE EXTERIOR.

CLEANING THE LUMBER

You should vacuum or brush out your sauna periodically to remove loose dirt. Over time the floor and seats of your sauna may discolor due to perspiration, dirt and general wear. You can remove dirt or stains with a solution of baking soda and water, lightly scrubbing the wood with the solution and then rinsing. Heavier stains or scuffs can be sanded out with fine grit sandpaper. Alternatively, pressure washing the interior of the sauna with a low-pressure, wide pattern nozzle will remove stains and dirt very effectively.

LOCATION AND GEOGRAPHY

Climate and temperature affect the lumber in different ways and to varying degrees. The effects of swelling and contraction as well as fading from sunlight will vary depending on the intensity of the sun and the levels of humidity and amounts of moisture in your area. The degree of these effects will not affect the quality or performance of your sauna, but may require you to tighten bands or re-stain your sauna more or less frequently. It is a good idea to check the tension of your bands and examine the degree of fading every few months, especially in the first months of owning your sauna so that you can respond accordingly.

REPLACEMENT OF SAUNA STONES

Over time your sauna stones may crack and split due to the fluctuations in temperature the stones experience. If you ever need to replace stones, only use sauna stones designed for use in your sauna heater. You can purchase replacement stones from RateOutdoors Saunas at any time.

REPLACEMENT PARTS

If you ever damage the exterior of the sauna, you can purchase replacement staves, doors, and components from Almost Heaven Saunas at any time.

This product manufactured by

**ALMOST HEAVEN**
SAUNAS